

OWNER'S MANUAL

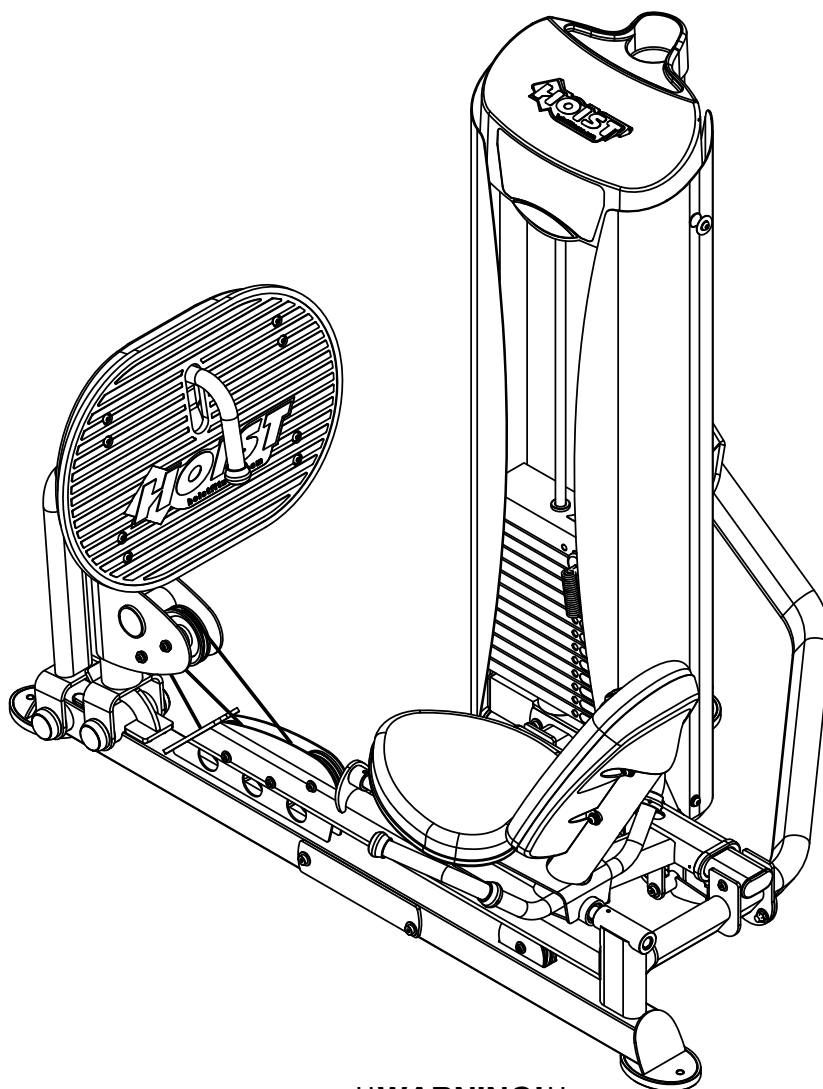

HD-3403

LEG PRESS / TOE RAISE



****WARNING!****

TO PREVENT POSSIBLE TIPPING, BOLT THIS UNIT TO THE EXERCISE FLOOR. FAILURE TO DO SO MAY RESULT IN SERIOUS INJURY OR DEATH.

Note: Both Serial Number and Model Number are Required when Ordering Parts

RECORD SERIAL NUMBER HERE

MACHINE CODE

A02

Customer Service

(800) 548-5438

(858) 578-7676

Fax

(858) 578-9558



www.facebook.com/hoistfitness

OWNER'S MANUAL

CONTENTS

INSTRUCTIONS	02
FRAME ASSEMBLY	04
PRE-ASSEMBLY.....	22
DECAL PLACEMENT.....	23
DECAL REFERENCE.....	24
PART LIST.....	26
ABBREVIATIONS.....	29
BOLT SIZING CHART.....	30
WASHER SIZING CHART.....	31
MAINTENANCE SCHEDULE.....	33
GENERAL MAINTENANCE INFORMATION.....	34
WEIGHT TRAINING TIPS.....	35
WEIGHT RATIOS.....	36
EXERCISE LOG.....	37
LIMITED WARRANTY.....	38

OWNER'S MANUAL

INSTRUCTIONS

Before beginning assembly please take the time to read instructions thoroughly. Please use the various lists in this manual to make sure that all parts have been included in your shipment. When ordering, use part number and description from the lists. Use only HOIST replacement parts when servicing. Failure to do so will void your warranty and could result in personal injury.

HOIST equipment is designed to provide the smoothest, most effective exercise motion possible. After assembly, you should check all functions to ensure correct operation. If you experience problems, first recheck the assembly instructions to locate any possible errors made during assembly. If you are unable to correct the problem, call your authorized HOIST dealer. Be sure to have your serial number and this manual when calling. When all parts have been accounted for, continue on.

TOOLS REQUIRED

Ratchet Wrench

1/2", 9/16" and 3/4" Sockets

Adjustable Wrench

Rubber Mallet

Tape Measure

Level

Hex Key Wrench Set

Two People

OWNER'S MANUAL

THIS PAGE WAS INTENTIONALLY LEFT BLANK

OWNER'S MANUAL

FRAME ASSEMBLY

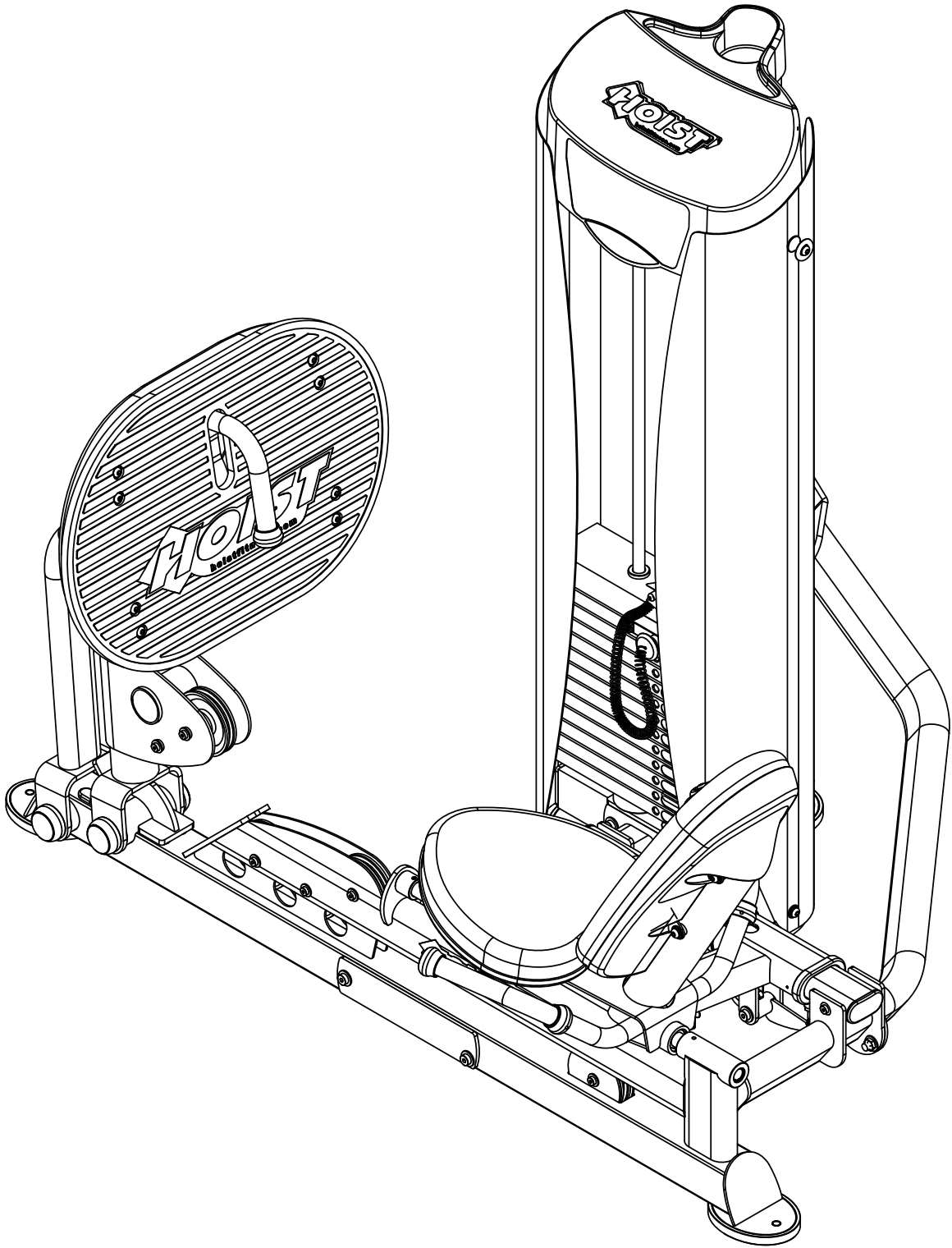

OWNER'S MANUAL

FRAME ASSEMBLY

CABLE PROFILE VIEW

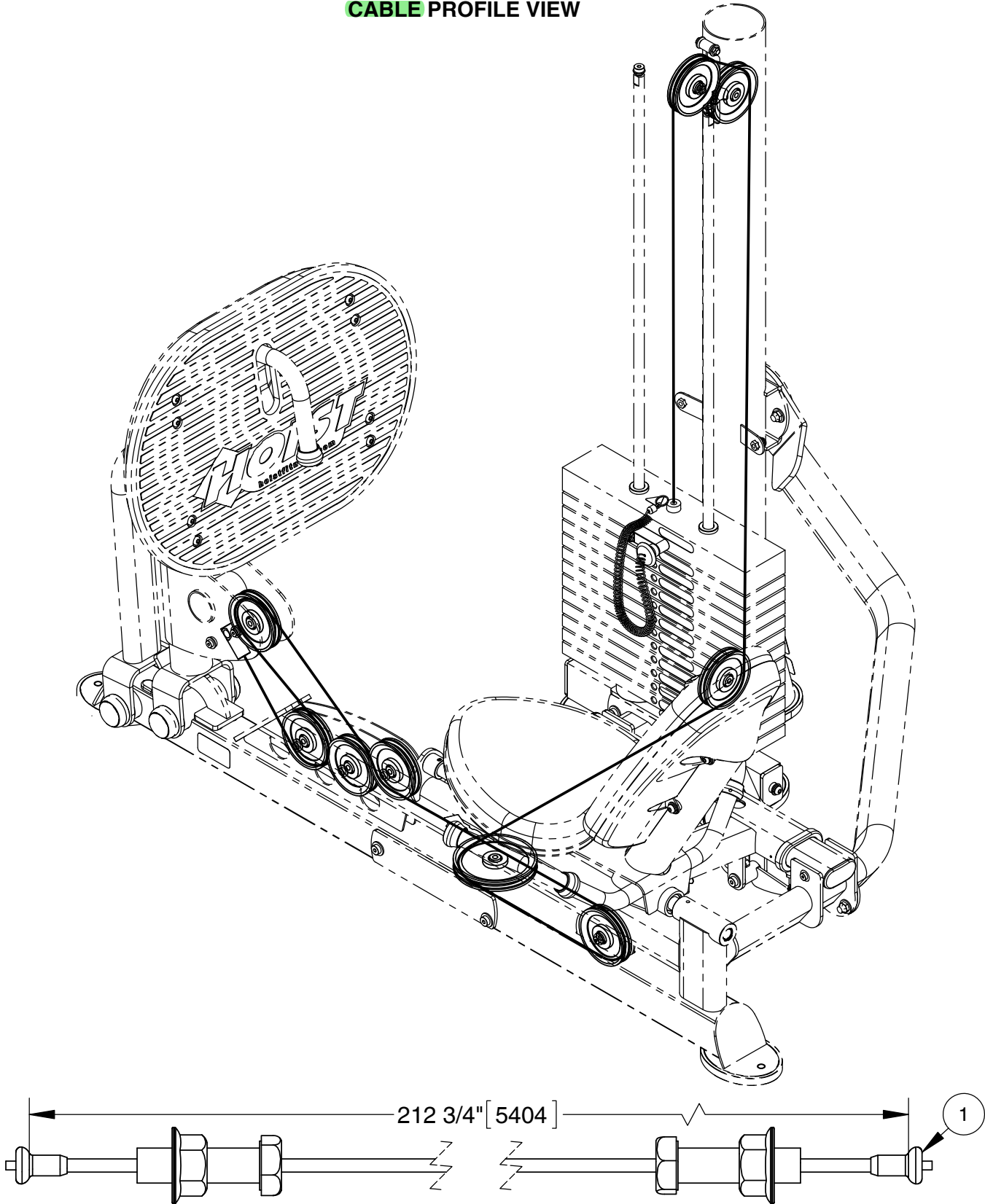

OWNER'S MANUAL

FRAME ASSEMBLY *ASSEMBLE WEIGHT CAGE FIRST*

- NOTE:
- WRENCH TIGHTEN HARDWARE (62).
 - HAND TIGHTEN HARDWARE.
 - INSTALL **CABLE** AND PULLEYS AT THE SAME TIME.
 - SOME PARTS MAY HAVE BEEN REMOVED FOR CLARITY.

THIS UNIT CAN USE:
WEIGHT STACK #13
OR
WEIGHT STACK #5
(REQUIRES **CABLE** 010-01C0663)

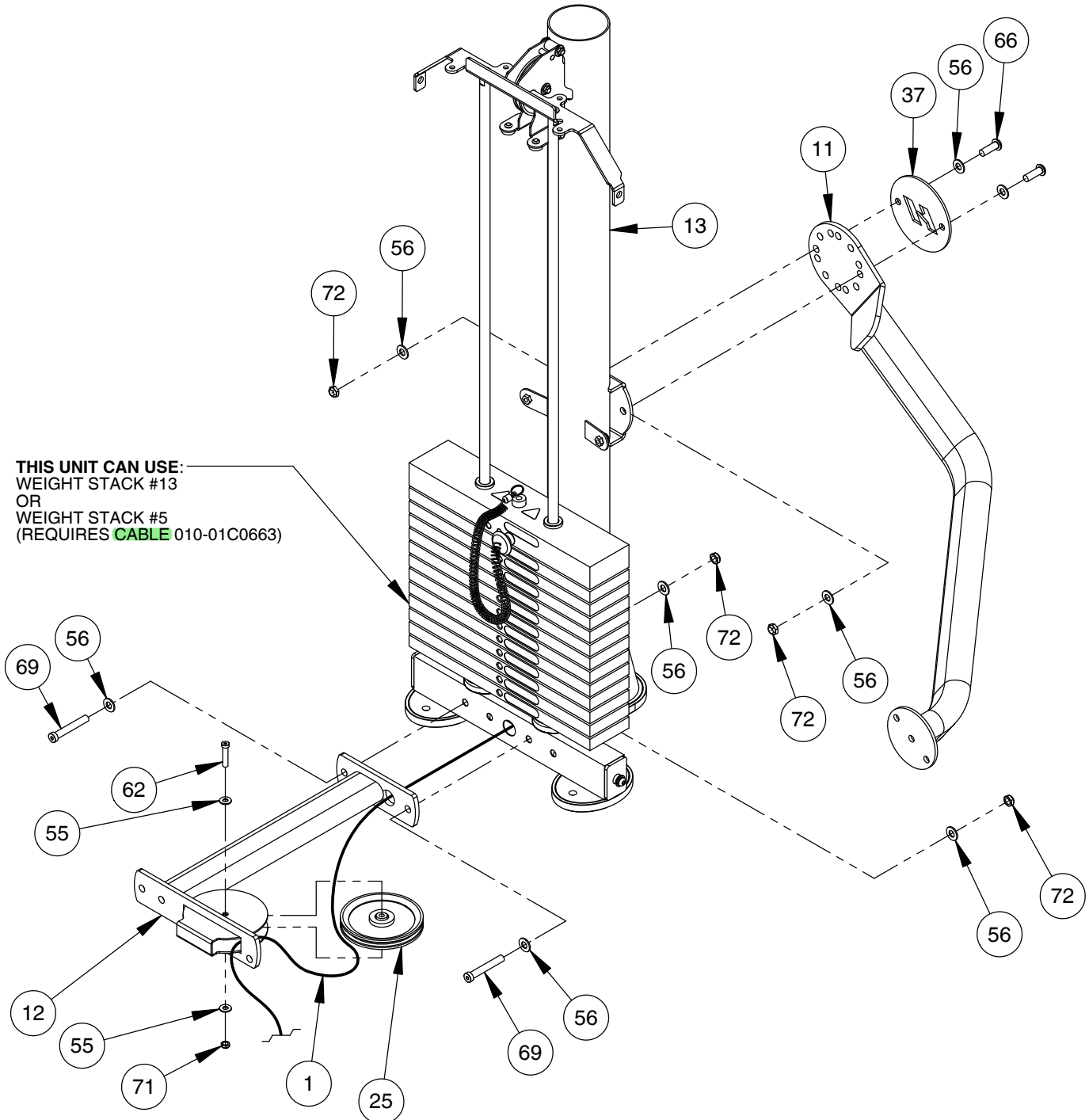

OWNER'S MANUAL

FRAME ASSEMBLY

NOTE:
- HAND TIGHTEN ALL HARDWARE.

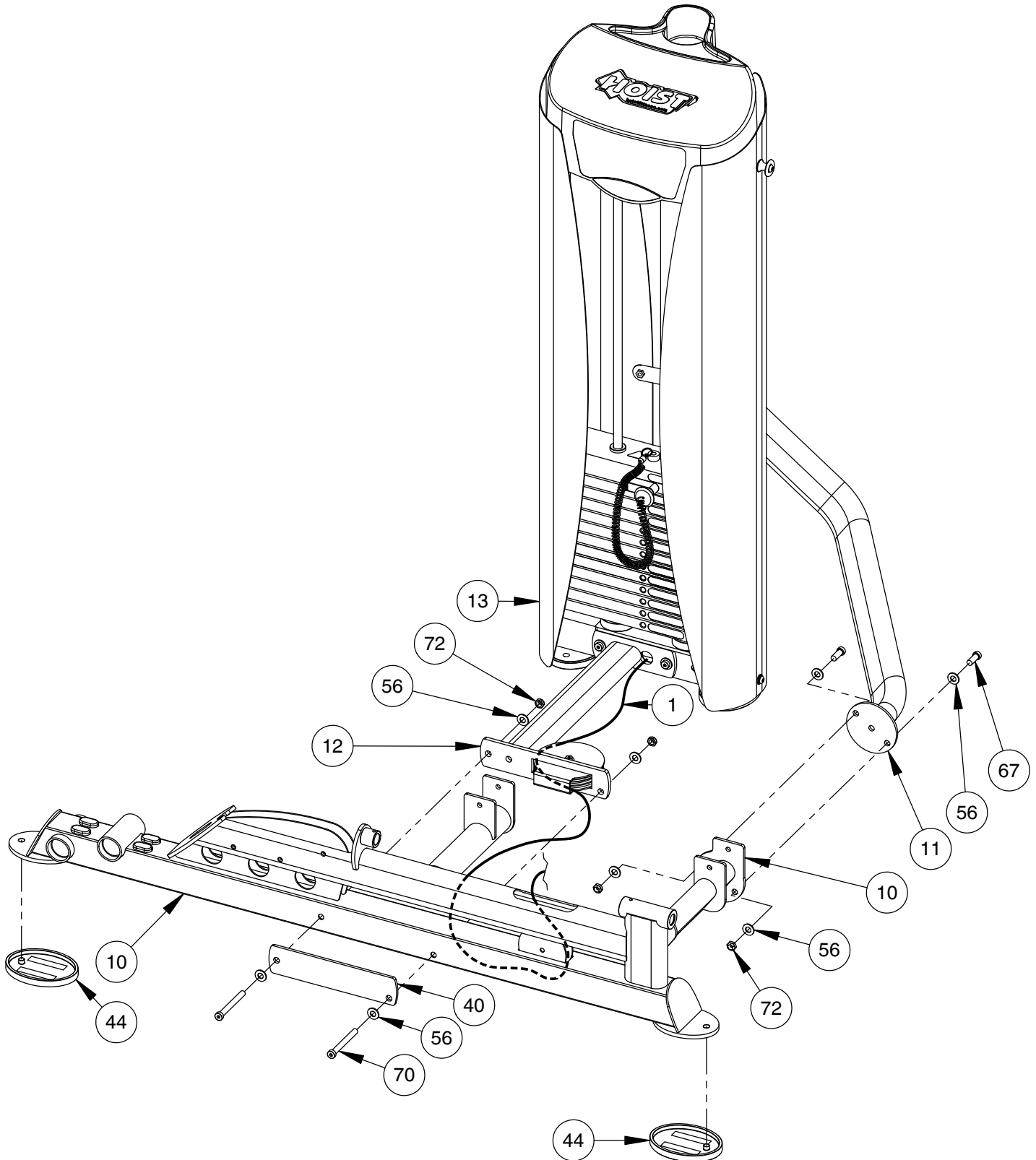

OWNER'S MANUAL

FRAME ASSEMBLY

CABLE INSTALLATION

MAJOR ADJUSTMENT:

LOOSEN JAM NUT AND THREAD THE STOP IN/OUT TO GIVE THE CABLE PROPER TENSION. RE-TIGHTEN JAM NUT.

WARNING - CABLE BOLT MUST BE THREADED A MINIMUM OF 3/8" WITH JAM NUT TIGHTENED SECURELY TO ENSURE PROPER CONNECTION.

NOTE:

- WRENCH TIGHTEN HARDWARE.
- SOME PARTS MAY HAVE BEEN REMOVED FOR CLARITY.
- INSTALL CABLES AND PULLEY AT SAME TIME.

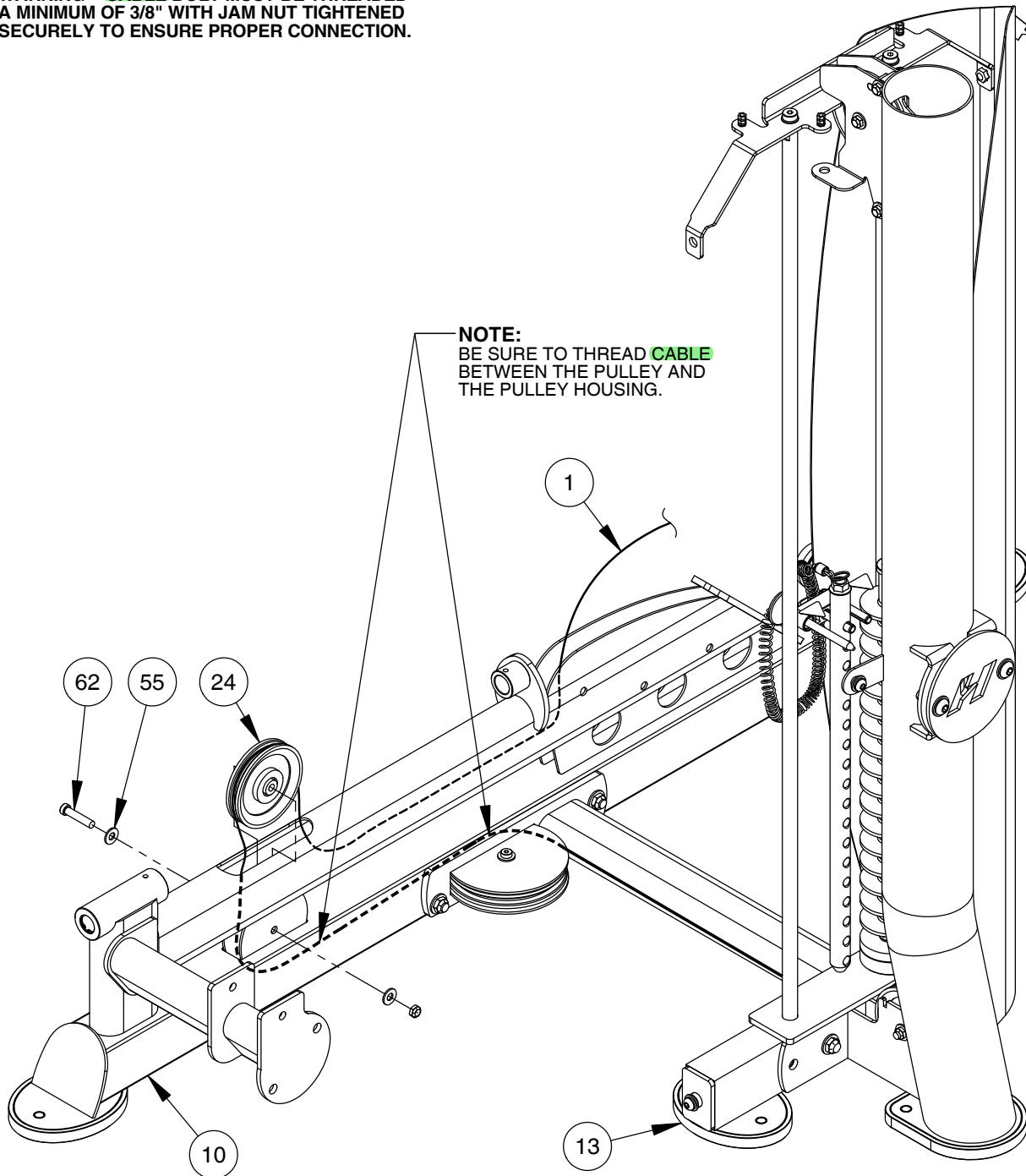

OWNER'S MANUAL

FRAME ASSEMBLY

NOTE:
- HAND TIGHTEN HARDWARE.
- SOME PARTS MAY HAVE BEEN
REMOVED FOR CLARITY.

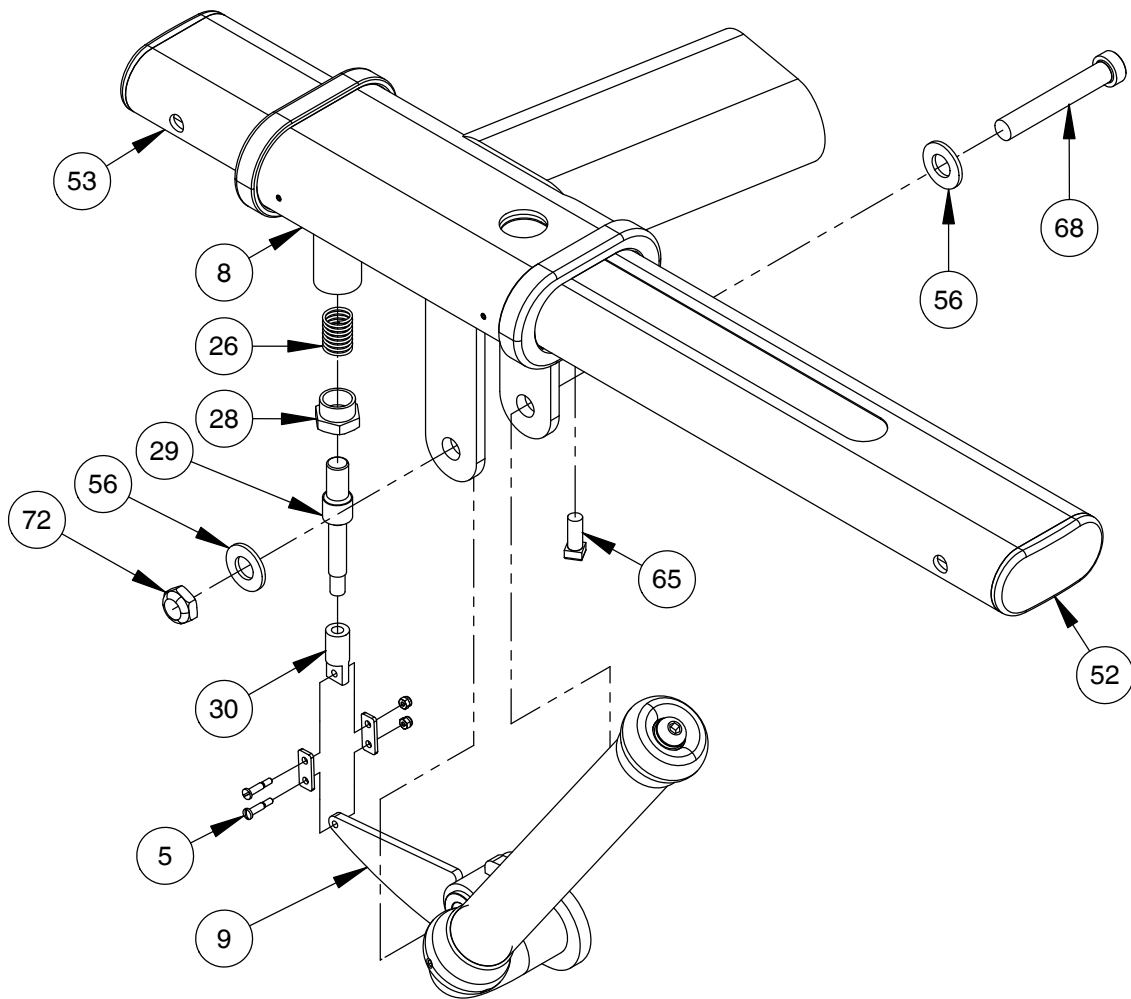

OWNER'S MANUAL

FRAME ASSEMBLY

NOTE:
- HAND TIGHTEN HARDWARE.
- SOME PARTS MAY HAVE BEEN
REMOVED FOR CLARITY.

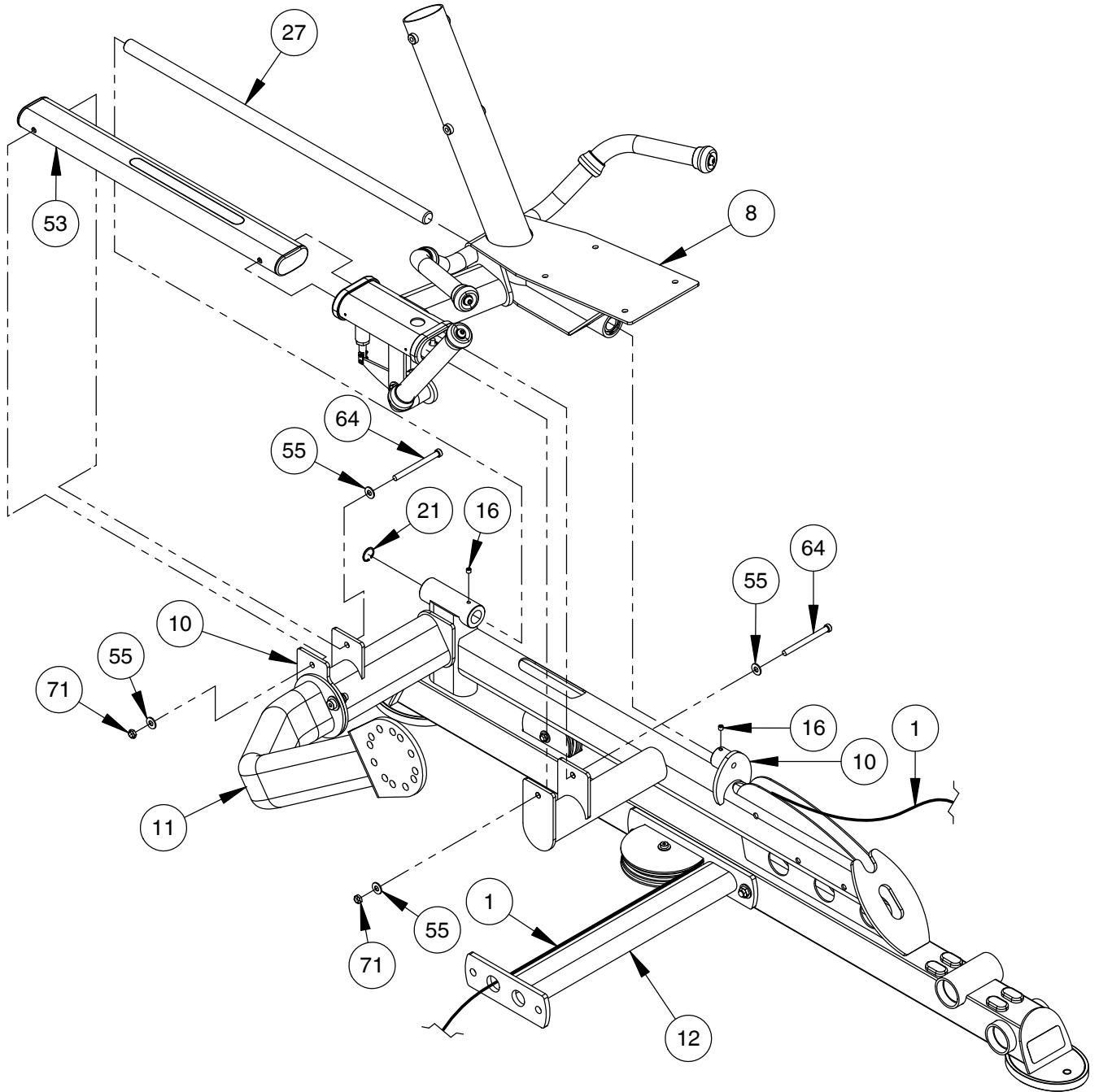

OWNER'S MANUAL

FRAME ASSEMBLY

NOTE:
- HAND TIGHTEN HARDWARE.
- SOME PARTS MAY HAVE BEEN REMOVED FOR CLARITY.

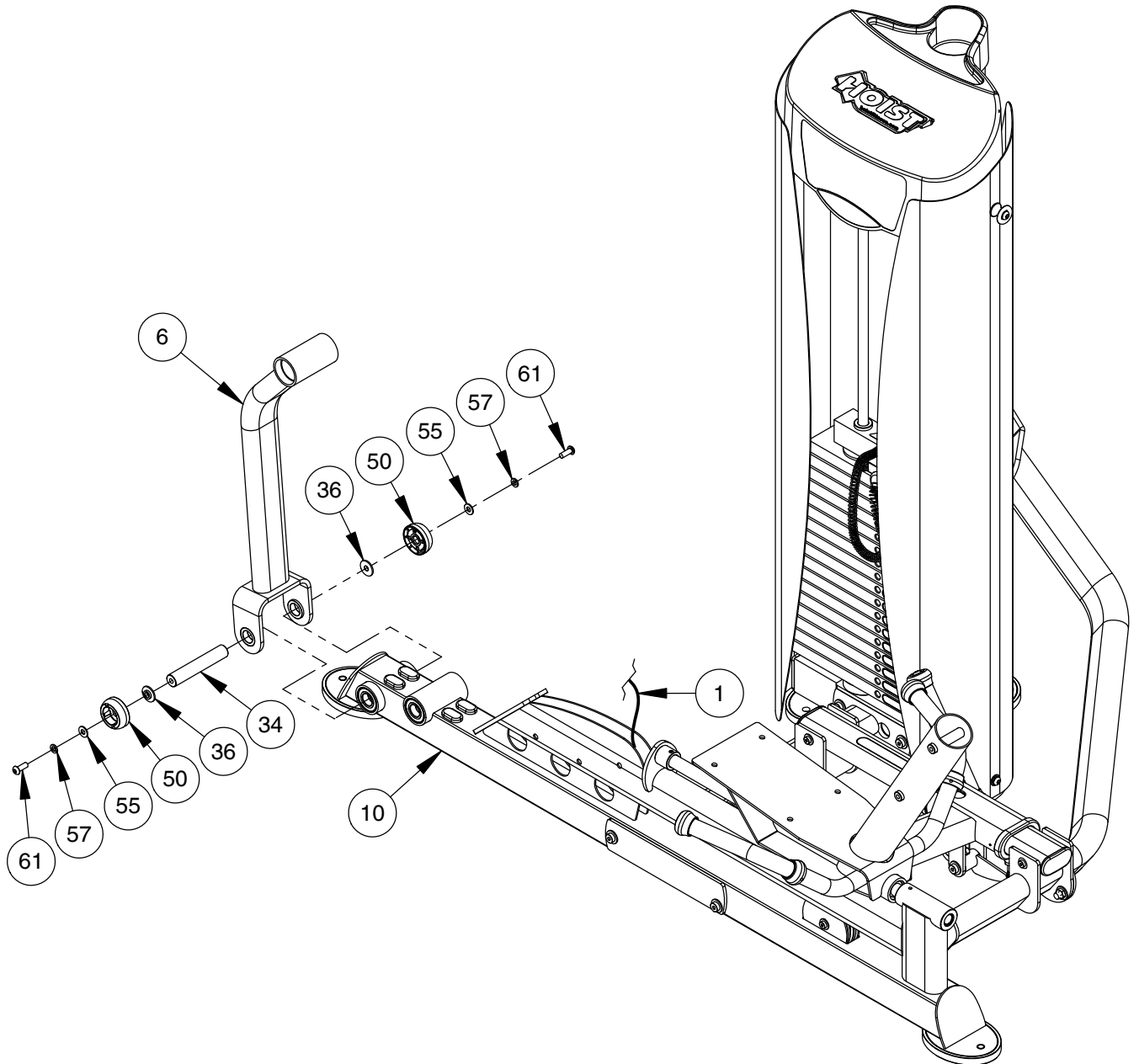

OWNER'S MANUAL

FRAME ASSEMBLY

NOTE:
- HAND TIGHTEN HARDWARE.
- SOME PARTS MAY HAVE BEEN
REMOVED FOR CLARITY.

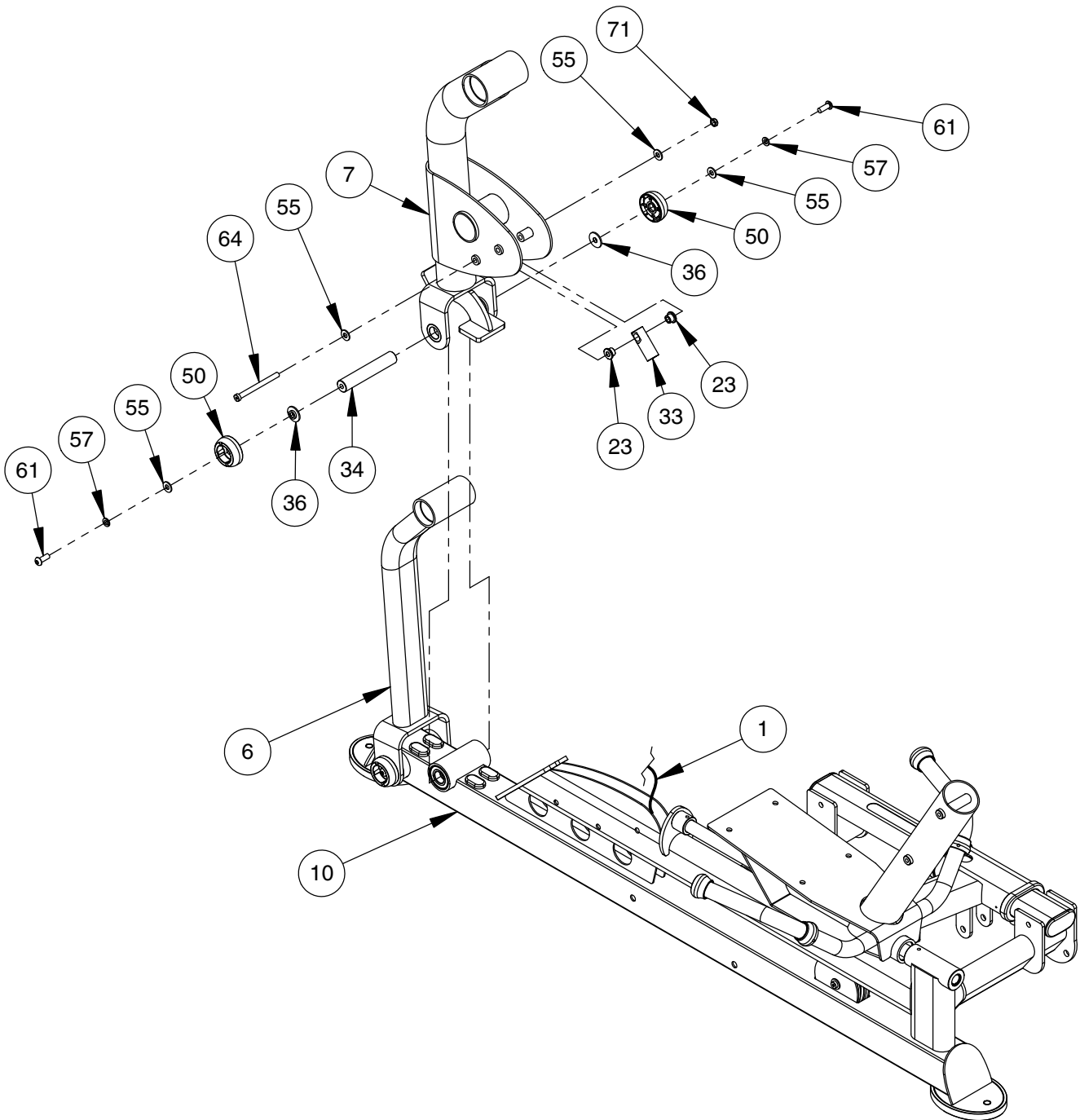

OWNER'S MANUAL

FRAME ASSEMBLY

NOTE:

- WRENCH TIGHTEN HARDWARE.
- SOME PARTS MAY HAVE BEEN REMOVED FOR CLARITY.
- INSTALL CABLES AND PULLEY AT SAME TIME.

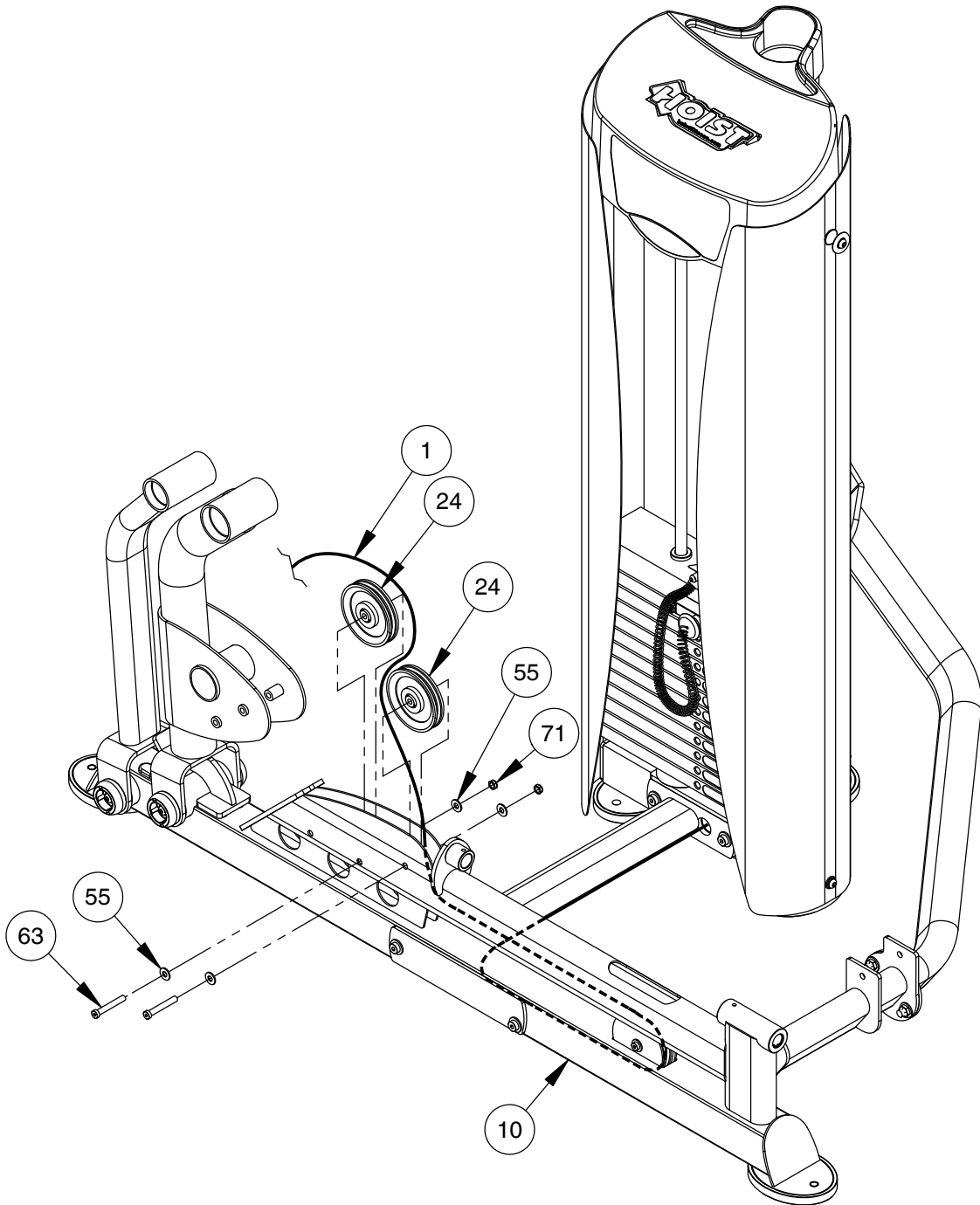

OWNER'S MANUAL

FRAME ASSEMBLY

CABLE INSTALLATION

MAJOR ADJUSTMENT:

LOOSEN JAM NUT AND THREAD THE STOP IN/OUT TO GIVE THE CABLE PROPER TENSION. RE-TIGHTEN JAM NUT.

WARNING - CABLE BOLT MUST BE THREADED A MINIMUM OF 3/8" WITH JAM NUT TIGHTENED SECURELY TO ENSURE PROPER CONNECTION.

NOTE:

- WRENCH TIGHTEN HARDWARE.
- SOME PARTS MAY HAVE BEEN REMOVED FOR CLARITY.
- INSTALL CABLES AND PULLEY AT SAME TIME.

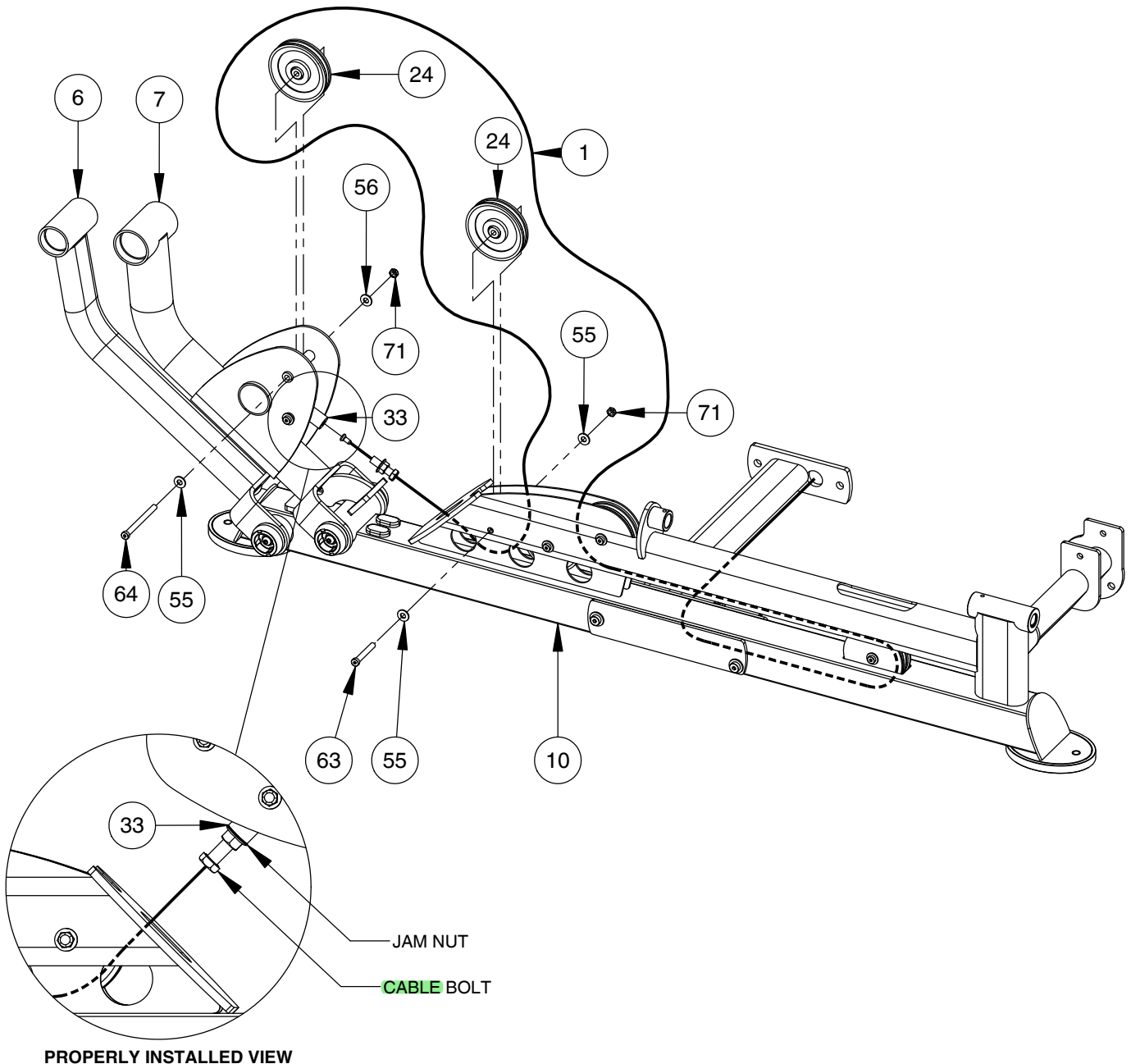

OWNER'S MANUAL

FRAME ASSEMBLY

NOTE:
- WRENCH TIGHTEN HARDWARE.
- SOME PARTS MAY HAVE BEEN
REMOVED FOR CLARITY.

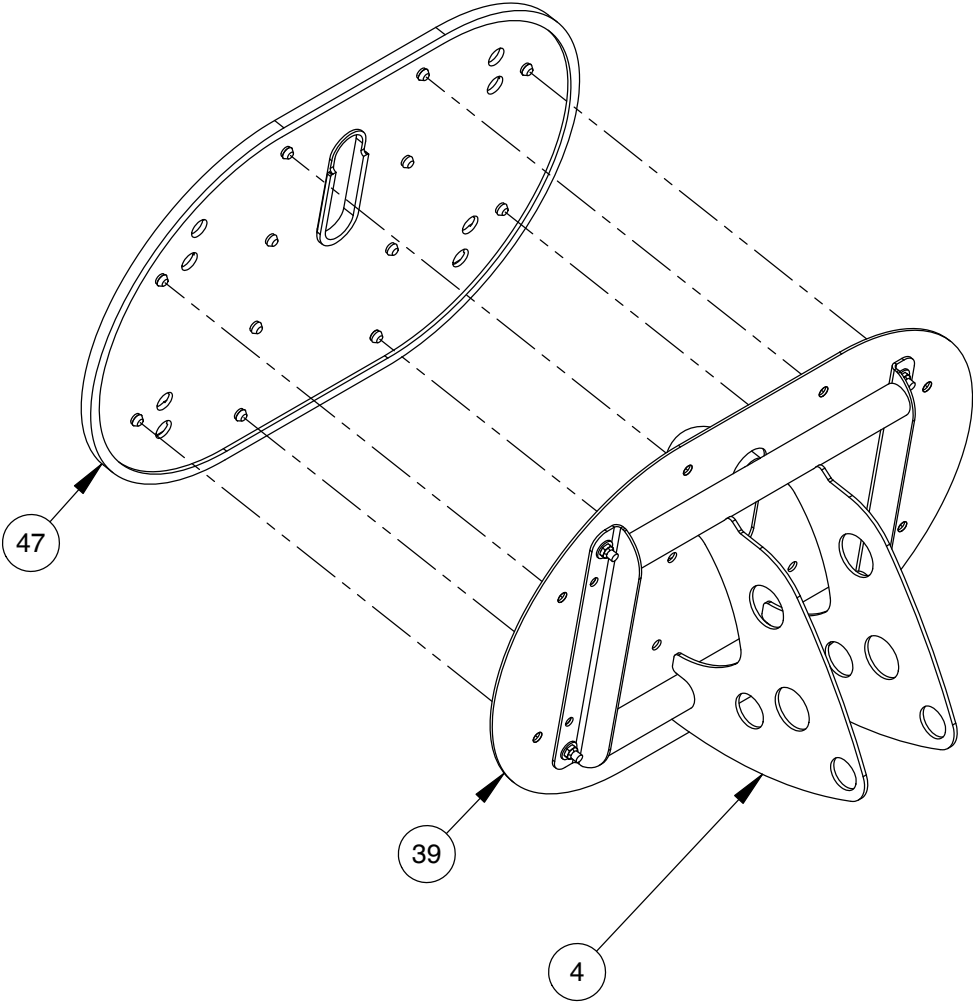

OWNER'S MANUAL

FRAME ASSEMBLY

NOTE:
- WRENCH TIGHTEN HARDWARE.
- SOME PARTS MAY HAVE BEEN
REMOVED FOR CLARITY.

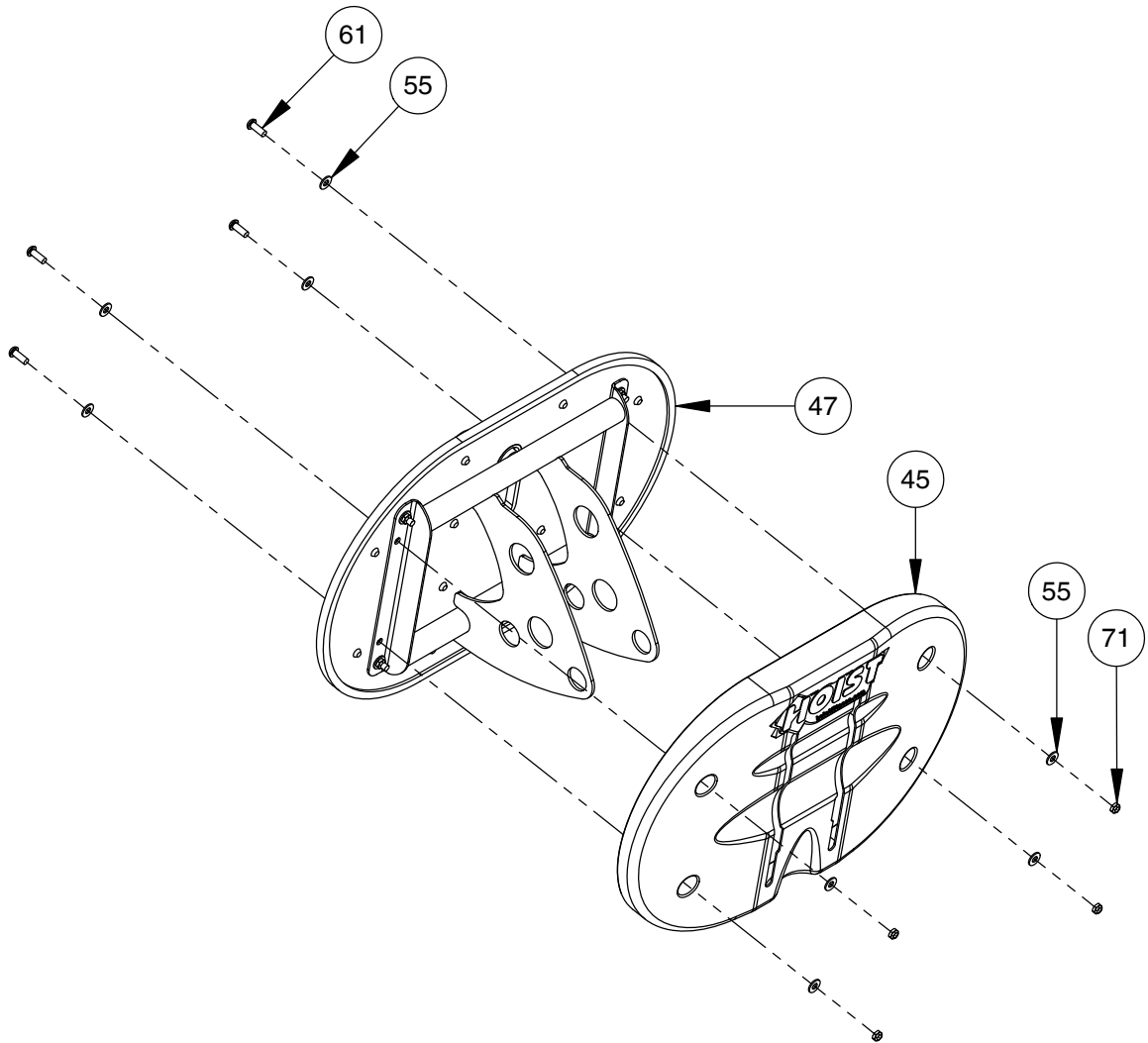

OWNER'S MANUAL

FRAME ASSEMBLY

NOTE:
- WRENCH TIGHTEN HARDWARE.
- SOME PARTS MAY HAVE BEEN
REMOVED FOR CLARITY.

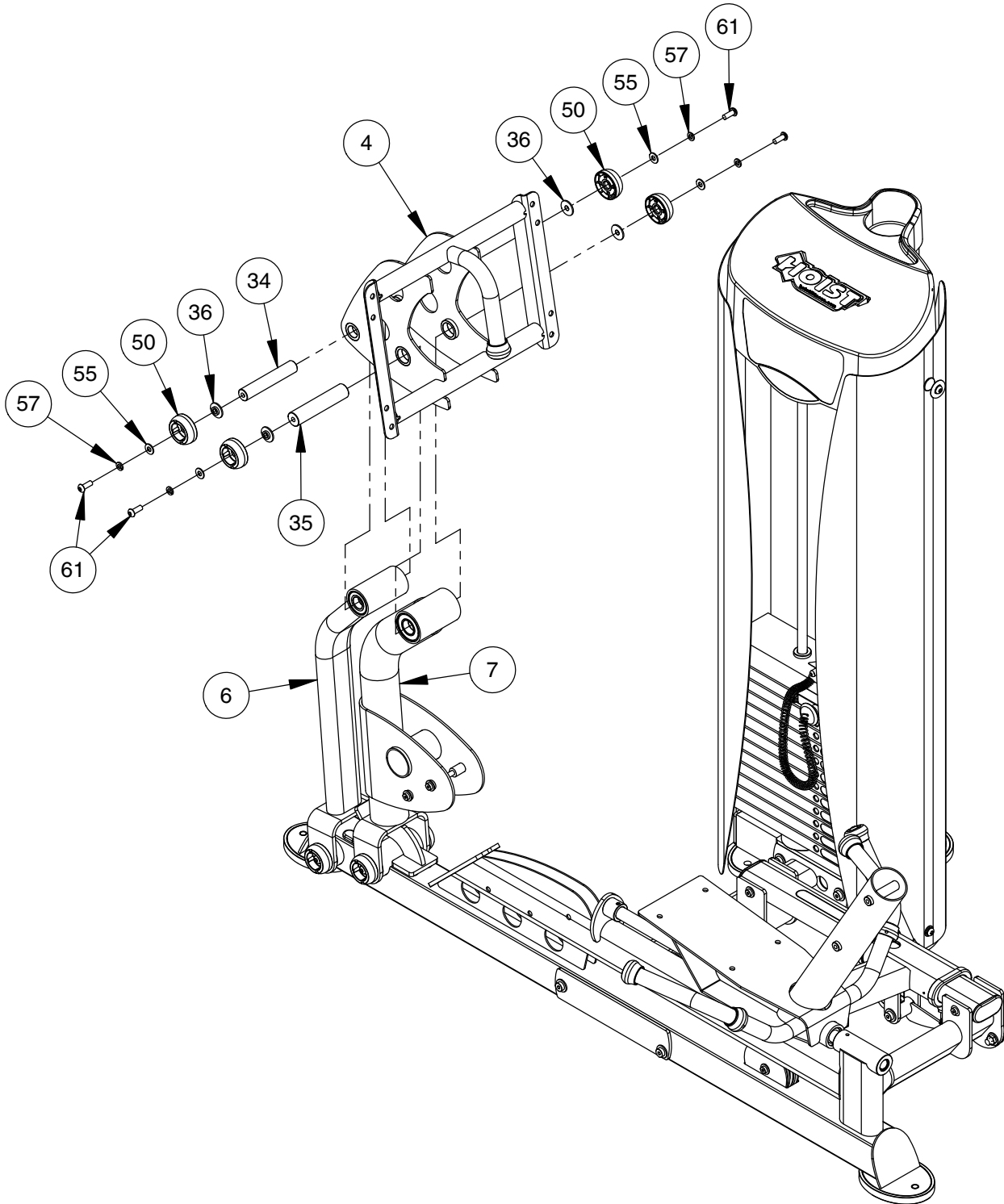

OWNER'S MANUAL

FRAME ASSEMBLY

NOTE:
- WRENCH TIGHTEN HARDWARE.
- SOME PARTS MAY HAVE BEEN
REMOVED FOR CLARITY.

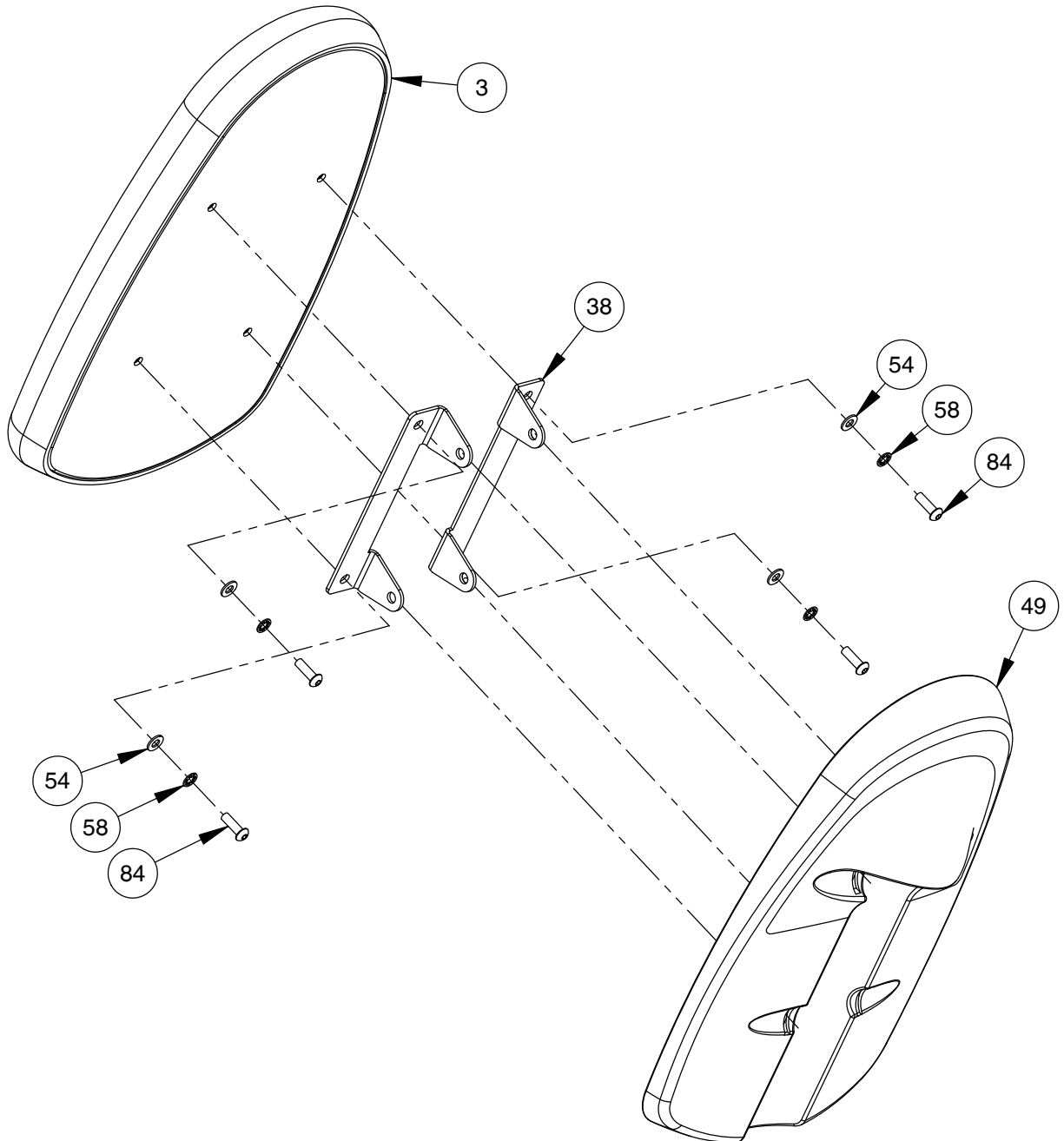

OWNER'S MANUAL

FRAME ASSEMBLY

NOTE:
- WRENCH TIGHTEN HARDWARE.
- SOME PARTS MAY HAVE BEEN
REMOVED FOR CLARITY.

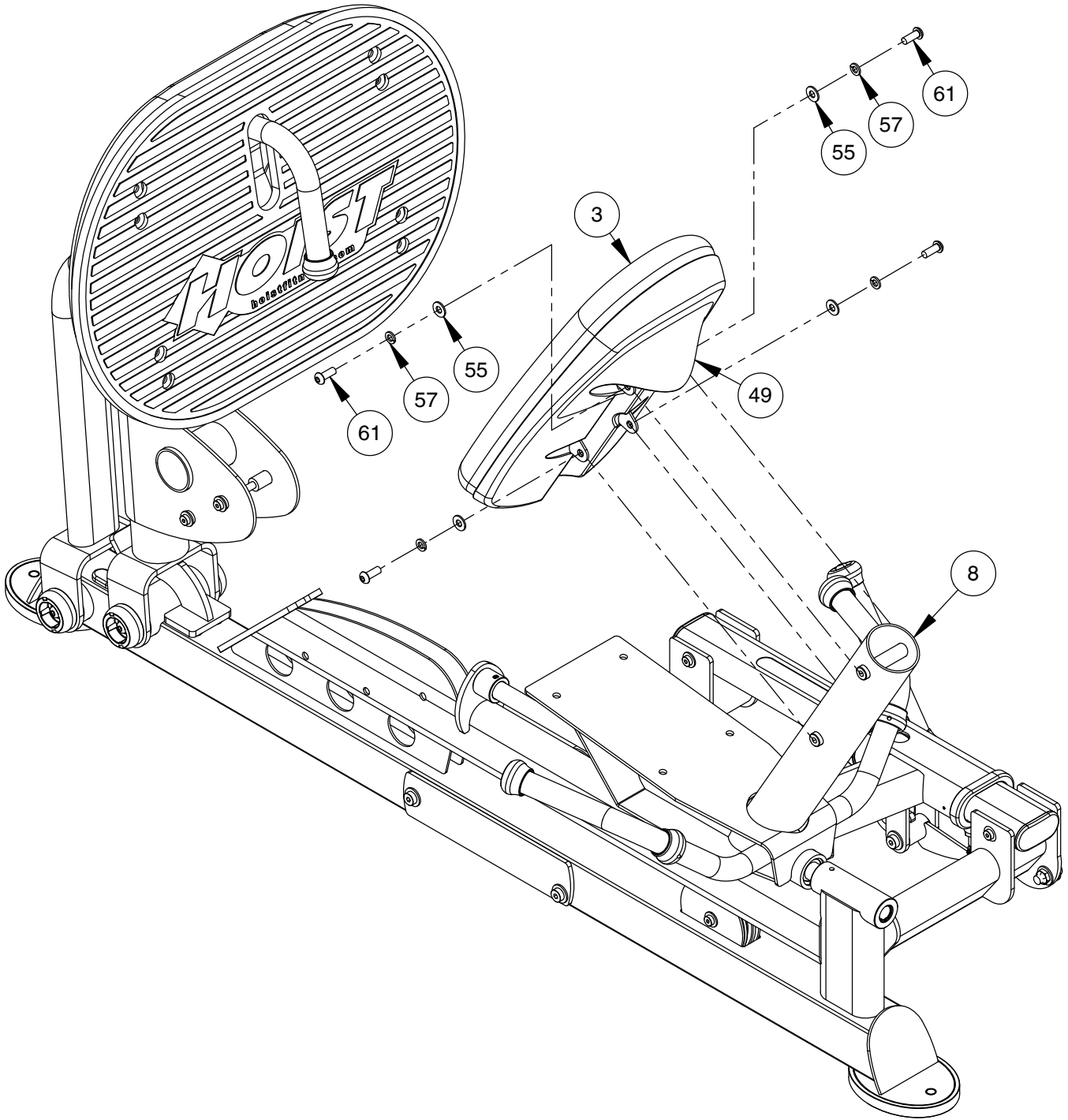

OWNER'S MANUAL

FRAME ASSEMBLY

NOTE:
- WRENCH TIGHTEN HARDWARE.
- SOME PARTS MAY HAVE BEEN
REMOVED FOR CLARITY.

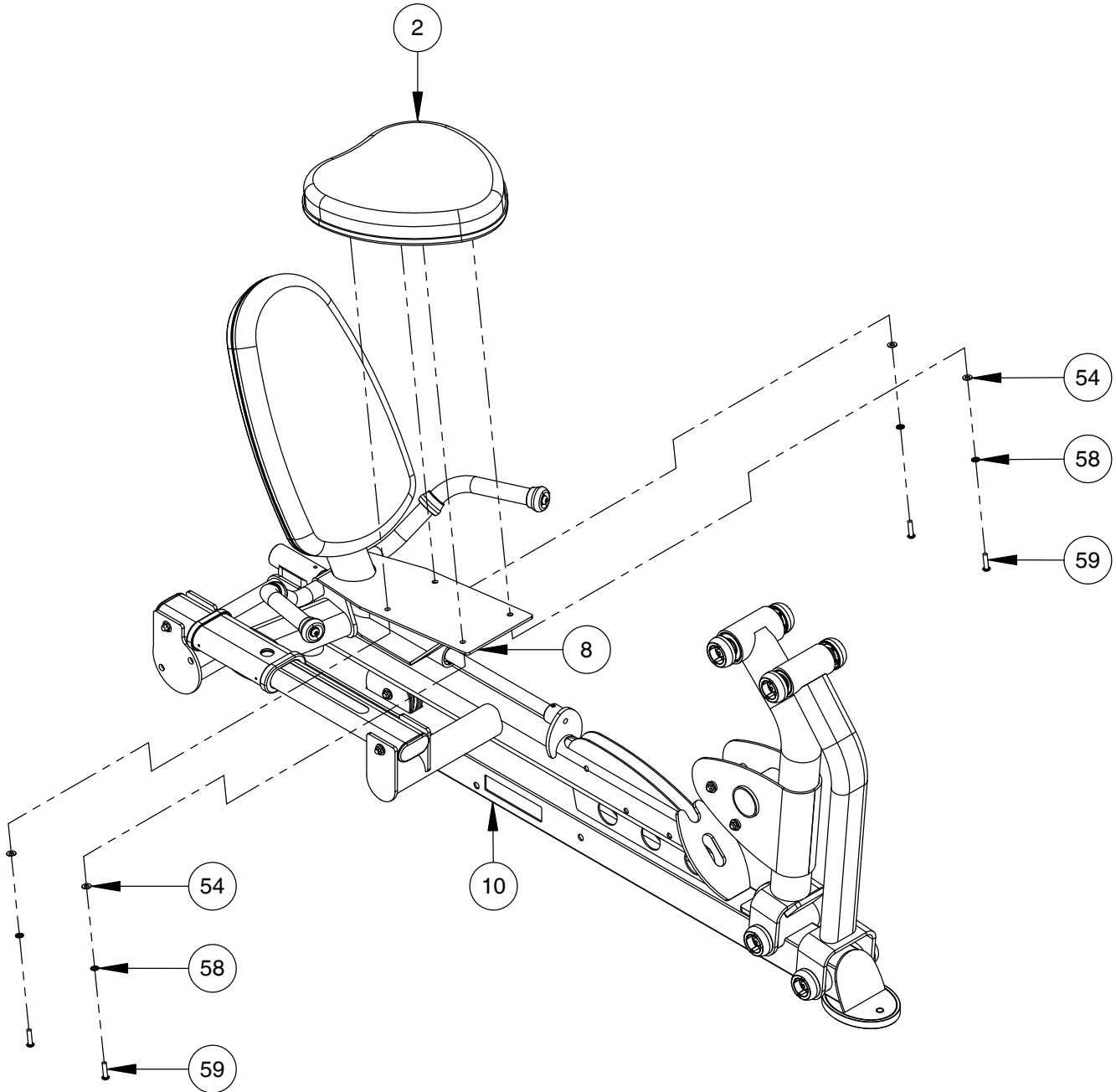

OWNER'S MANUAL

FRAME ASSEMBLY

NOTE:
- WRENCH TIGHTEN HARDWARE.
- SOME PARTS MAY HAVE BEEN
REMOVED FOR CLARITY.

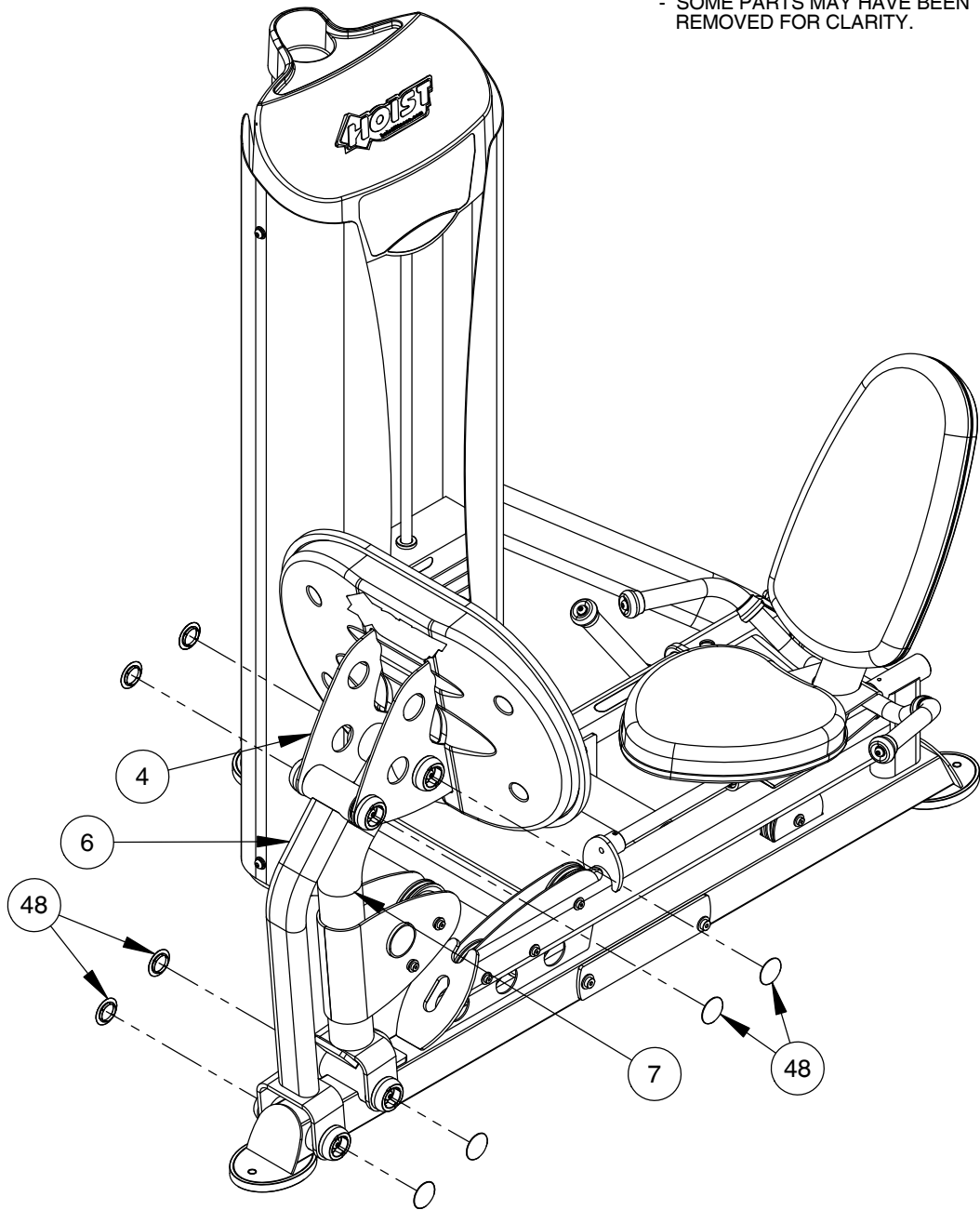

IMPORTANT

NOW THAT THE HD-3403 IS COMPLETELY ASSEMBLED TAKE TIME TO ASSURE THAT YOUR UNIT IS ASSEMBLED SQUARE AND PERPENDICULAR. IF NOT, IT WILL BE NECESSARY TO LOOSEN SOME FRAME HARDWARE TO RE-ALIGN THE FRAME AND RETIGHTEN BOLTS.

OWNER'S MANUAL

PRE-ASSEMBLY

NOTE:
- WRENCH TIGHTEN HARDWARE.

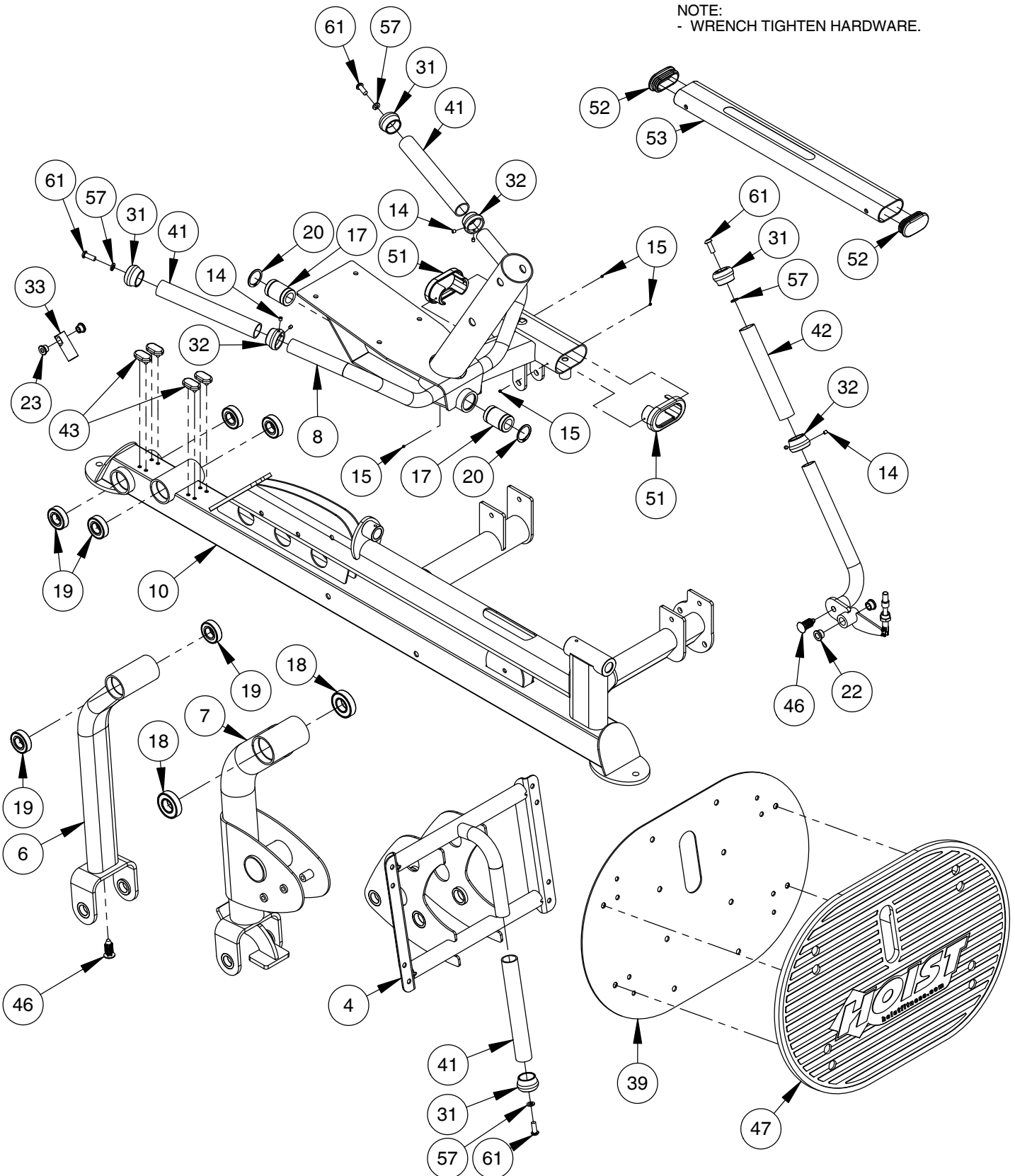

OWNER'S MANUAL

DECAL PLACEMENT

NOTE:
- ALL DECALS ARE CENTERED
UNLESS OTHERWISE STATED.

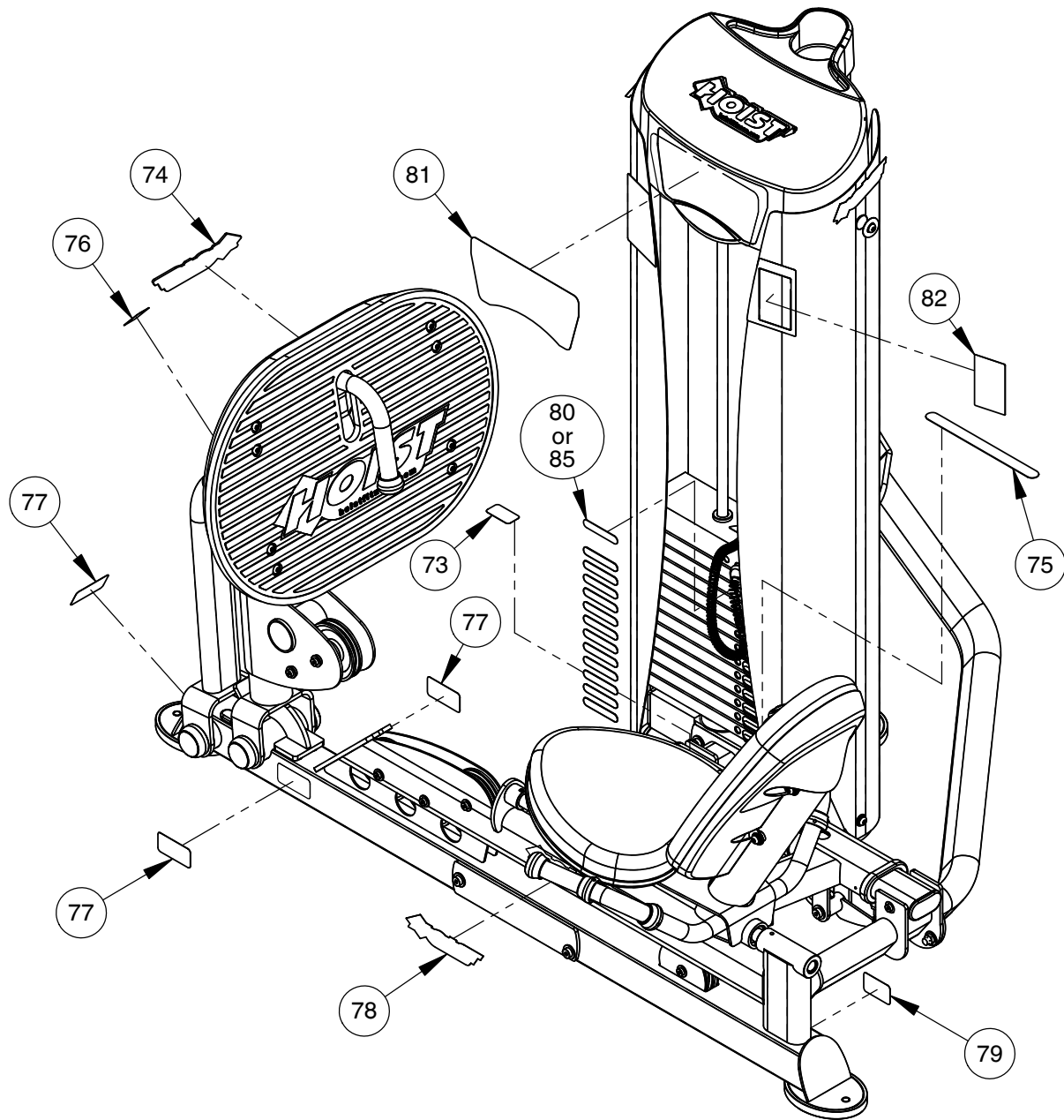

OWNER'S MANUAL

DECAL REFERENCE

LEG PRESS

MAIN MUSCLE: QUADRICEPS

- 1 Adjust the seat to the desired start position; 90 degree bend at the knee recommended.
- 2 Hold onto the handles for support.
- 3 Press your legs forward, leaving a slight bend in your knees when extended. Repeat.

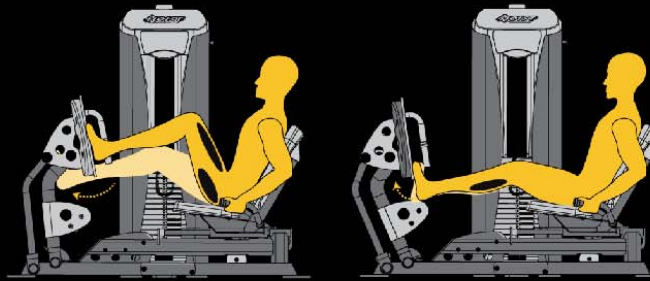

CALF RAISE

MAIN MUSCLE: CALVES

- 1 Adjust the seat so your legs are slightly bent and your heels are placed slightly below the bottom of the foot plate.
- 2 Fully extend your legs without locking your knees and hold the position.
- 3 Flex your toes forward as far as possible. Repeat.

021-0003884

TO VISIT THE HOIST® MOBILE APPLICATION, SCAN THE QR CODE* BELOW WITH YOUR SMARTPHONE'S CAMERA.

THE APPLICATION PROVIDES A SHORT VIDEO, ALONG WITH ANSWERS TO:

- HOW DO I ADJUST THIS MACHINE?
- HOW DO I PERFORM THE EXERCISE?
- WHERE IS HOIST ON THE WEB?

SCAN HERE:



* USING YOUR SMARTPHONE, VISIT WWW.HOISTFITNESS.COM/SCAN TO DOWNLOAD A FREE QR CODE SCANNER.

021-003915

021-0003915



021-0003627



021-0003114



021-0003322



1-800-548-5438
www.hoistfitness.com
SERIAL # 00-00-A-000000



SERIAL # DECAL

OWNER'S MANUAL

DECAL REFERENCE

40 LBS / 18 KGS

200 LBS / 91 KGS

360 LBS / 163 KGS

60 LBS / 27 KGS

220 LBS / 100 KGS

380 LBS / 172 KGS

80 LBS / 36 KGS

240 LBS / 109 KGS

021-0003932

100 LBS / 45 KGS

260 LBS / 118 KGS

120 LBS / 54 KGS

280 LBS / 127 KGS

140 LBS / 64 KGS

300 LBS / 136 KGS

160 LBS / 73 KGS

320 LBS / 145 KGS

180 LBS / 82 KGS

340 LBS / 154 KGS

40 LBS / 18 KGS

200 LBS / 91 KGS

60 LBS / 27 KGS

220 LBS / 100 KGS

80 LBS / 36 KGS

240 LBS / 109 KGS

100 LBS / 45 KGS

260 LBS / 118 KGS

120 LBS / 54 KGS

280 LBS / 127 KGS

140 LBS / 64 KGS

021-0003901

160 LBS / 73 KGS

180 LBS / 82 KGS



021-0003543



021-0003913



021-0018022

OWNER'S MANUAL

PART LIST

NOTE: SOME OF THESE PARTS MAY COME PRE-INSTALLED

ITEM NO.	PART NUMBER	DESCRIPTION	QTY.
1	010-01C0428	HD-3403 CABLE 220" LG	1
2	022-01PD2075-A	UPHOLSTERED SEAT PAD	1
3	022-01PD2114-A-M	BACK PAD ASSEMBLY	1
4	026-01X3967	FOOTPLATE MOUNT	1
5	026-01X5630	CHAIN LINK REPLACEMENT	1
6	026-01X5876	CONTROL LINK	1
7	026-01X5878	RESISTANCE ARM	1
8	026-01X5880	SEAT FRAME	1
9	026-01X5886	ADJUSTER HANDLE	1
10	026-01X6599	BASE ASSEMBLY	1
11	026-01X6601	CROSSBAR ASSEMBLY	1
12	026-01X6602	CROSSMEMBER	1
13	ROC-IT WEIGHT CAGE -63	ROC-IT WEIGHT CAGE	1
14	011-0711001	SET SCREW: 1/4"-28 X .25" LG. (Ni)	6
15	011-0111011	18-8 Cone Point Hex Socket Set Screw (Ni)	4
16	011-0311003	SET SCREW: 5/16-18 X .25" LG.	2
17	014-0007007	BEARING \varnothing 25mm (LINEAR) (WON)	2
18	014-0012013	BEARING: BALL BEARING \varnothing 2.44" O.D. X \varnothing 1.18" I.D.	2
19	014-0012014	BEARING: FLANGELESS - 25mm I.D.	6
20	014-0015005	SNAP RING: \varnothing 40mm INTERNAL	2
21	014-0015015	SNAP RING 1.00" INTERNAL	1
22	014-0101002	BUSHING: OILITE FLANGED \varnothing 3/4" O.D X \varnothing 1/2" I.D X 3/8" LG.	2
23	014-0101020	BUSHING: OILITE FLANGED \varnothing .63" O.D. X \varnothing .38" I.D. X .50" LG.	2
24	018-0001003	CABLE PULLEY: \varnothing 4.50"	5
25	018-0002017	PULLEY 6.00" OD	1
26	020-0011009	SPRING	1
27	026-01G0215	SHAFT, \varnothing .984" X 29.94" LG.	1
28	026-01M0128-1	PULL PIN CAP	1
29	026-01M0128-3	PULL-PIN PLUNGER	1
30	026-01M0209	PULL-PIN TO CHAIN LINK	1
31	026-01M0932	ALUMINIUM CAP: \varnothing 1.25" ID	4
32	026-01M0933	ALUMINUM RING: \varnothing 1.25" ID	3
33	026-01M1103	THREADED CABLE ANCHOR \varnothing 1" O.D X 2 1/2" LG.	1
34	026-01M2987	PIVOT SHAFT	3
35	026-01M2995	PIVOT SHAFT	1
36	026-01M3112	FINISHED CAP WASHER	8
37	026-01P2653	'H' PLATE	1

OWNER'S MANUAL

PART LIST

NOTE: SOME OF THESE PARTS MAY COME PRE-INSTALLED

ITEM NO.	PART NUMBER	DESCRIPTION	QTY.
38	026-01P2929	BACK BRACKET MOUNT	2
39	026-01P3936	FOOTPLATE	1
40	026-01P4538	FLANGE-F 1/4" X 2 3/4" X 5 1/2"	1
41	026-01PL0235-10	GRIP OPEN END ϕ 1.19" X 10.00" LG.	3
42	026-01PL0235-23	GRIP OPEN END ϕ 1.188" X 8.75" LG.	1
43	026-01PL2005	PLUG BUMPER (2 STEM)	4
44	026-01PL2122	OVAL-SHAPED RUBBER FOOT	2
45	026-01PL2177	FOOTPLATE	1
46	026-01PL2200	PINETREE PLUG	2
47	026-01PL2263	RUBBER FOOTPLATE COVER	1
48	026-01PL2371	3.75" ROLLER PAD END CAP	8
49	026-01PL2511	BACK PAD PLASTIC BACKING	1
50	026-01PL2553	FINISH CAP BODY, ϕ 2 3/8"	8
51	026-01PL2564	GLIDE SLEEVE	2
52	026-01PL2565	3.15" X 1.57" CAP	2
53	026-01T5768	ADJUSTER TUBE	1
54	013-1002010	5/16" SAE FLAT WASHER (Ni)	8
55	013-1002007	3/8" X 22mm FLAT WASHER (Ni)	46
56	013-1002006	1/2" X 27mm SAE FLAT WASHER (Ni)	18
57	013-1006003	3/8" SPLIT LOCK WASHER (Ni)	16
58	013-1010003	5/16" INTERNAL LOCK WASHER (Ni)	8
59	011-0701004	5/16"-18UNC X 1.25" BHCS (Ni)	4
61	011-0701020	3/8"-16UNC X 1.00" BHCS (Ni)	24
62	011-0116145	3/8"-16UNC X 1.75" LOW HEAD SHCS (Ni)	2
63	011-0116148	3/8"-16UNC X 2.50" LOW HEAD SHCS (Ni)	3
64	011-0116155	3/8"-16UNC X 4.25" LOW HEAD SHCS (Ni)	4
65	011-0704001	3/8"-16UNC X .75" SQUARE HEAD (Ni)	1
66	011-0701049	1/2"-13UNC X 1.50" BHCS (Ni)	2
67	011-0116108	1/2"-13UNC X 1.25" LOW HEAD SHCS (Ni)	2
68	011-0116115	1/2"-13UNC X 3.00" LOW HEAD SHCS (Ni)	1
69	011-0116116	1/2"-13UNC X 3.25" LOW HEAD SHCS (Ni)	2
70	011-0116120	1/2"-13UNC X 4.25" LOW HEAD SHCS (Ni)	2
71	012-0504005	3/8"-16 UNC THIN NYLOCK NUT (Ni)	17
72	012-0504002	1/2"-13 UNC THIN NYLOCK NUT (Ni)	9
73	021-0003322	DECAL PINCH POINT 1.25" X 2.31" (VERTICAL)	1
74	021-0018022	DECAL HOISTFITNESS.COM LOGO	1

OWNER'S MANUAL

PART LIST

NOTE: SOME OF THESE PARTS MAY COME PRE-INSTALLED

ITEM NO.	PART NUMBER	DESCRIPTION	QTY.
75	021-0003913	DECAL ADJUST 1-11 VERTICAL GREY BKGRND	1
76	021-0003543	DECAL MOVING PARTS 1.20" X 2.38" (VERTICAL)	1
77	021-0003114	DECAL PINCH POINT 1.63" X 3.25" (HORIZONTAL)	3
78	021-0003627	DECAL HOIST 2.07" X 7.75"	1
79	SERIAL # DECAL	DECAL SERIAL # 1.63" X 2.63"	1
80	021-0003901	HD-3403 WEIGHT STACK DECALS	1
81	021-0003884	PLACARD HD-3403 LEG PRESS/CALF RAISE	1
82	021-0003915	HD QR DECAL	1
83	021-0003914	DUAL SERIES EYEBALL DECAL	1
84	011-0701003	5/16"-18UNC X 1.00" BHCS (Ni)	4
85	021-0003932	HDG WEIGHT STACK DECAL #5	1

OWNER'S MANUAL

ABBREVIATIONS

BZ = Black Zinc
Ni = Nickel Plated
WZ = White Zinc
SS = Stainless Steel

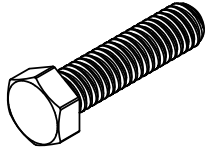

HHB = Hex Head Bolt

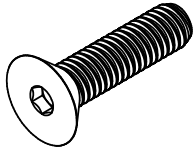

FHCS = Flat Head Cap Screw

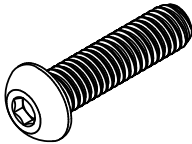

BHCS = Button Head Cap Screw

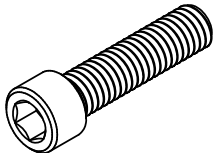

SHCS = Socket Head Cap Screw

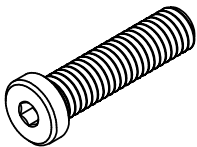

Low Head SHCS = Low Head Socket
Head Cap Screw

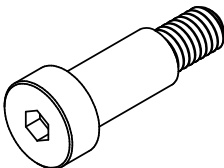

SHSS = Socket Head Shoulder Screw

OWNER'S MANUAL

BOLT SIZING CHART

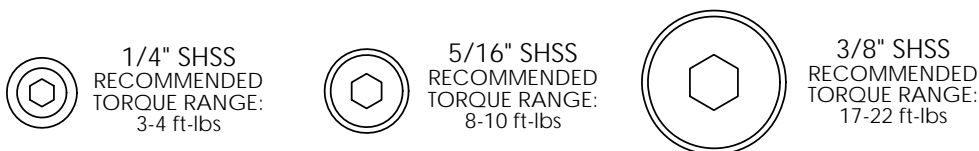
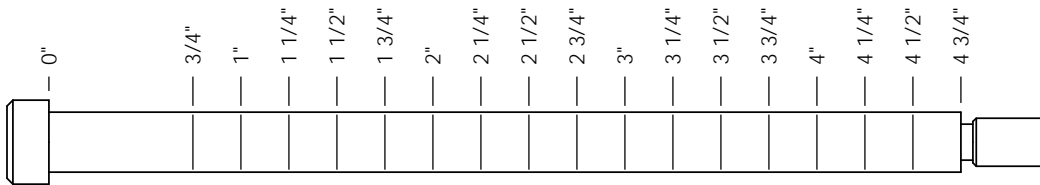
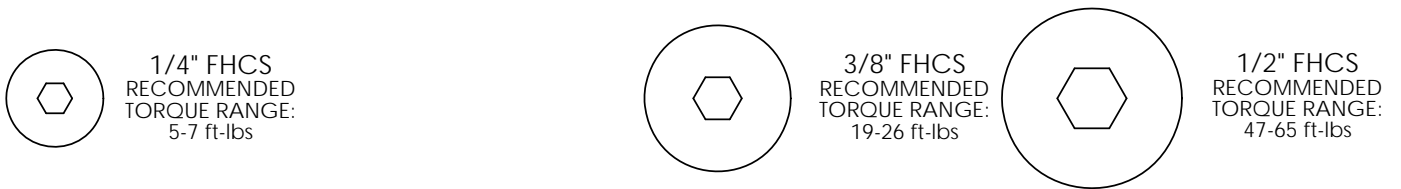
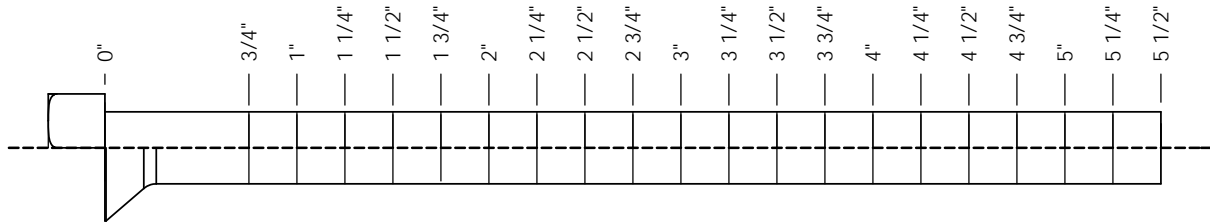
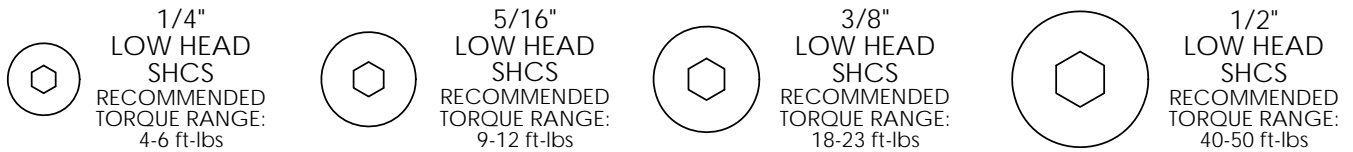
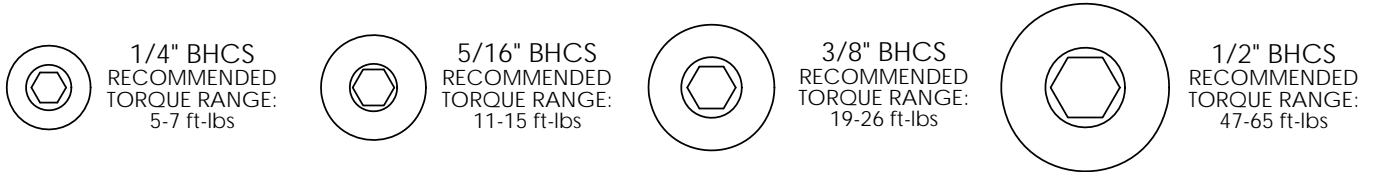
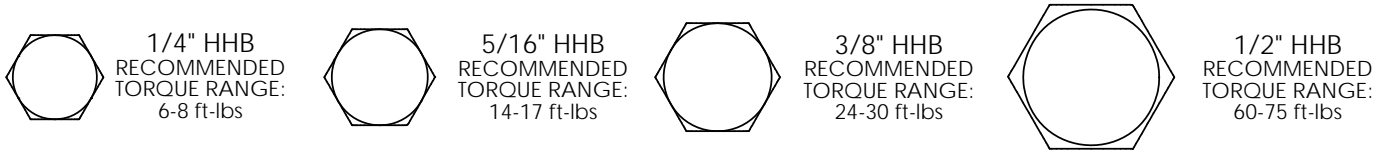

OWNER'S MANUAL

WASHER SIZING CHART

013-0002003
1/4"
FLAT WASHER
SMALL, SAE, 13mm

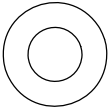

013-0102004
5/16"
FLAT WASHER
LARGE, USS, 22mm

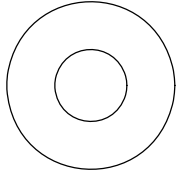

013-0002004
3/8"
FLAT WASHER
SMALL, SAE, 21mm

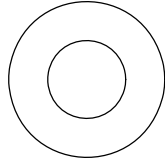

013-0402005
3/8"
FLAT WASHER
LARGE, USS, 25mm

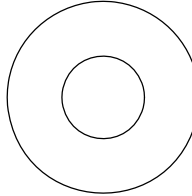

013-0102003
1/2"
FLAT WASHER
SMALL, SAE, 27mm

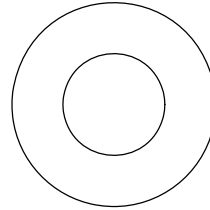

013-0102026
1/2"
FLAT WASHER
LARGE, USS, 34mm

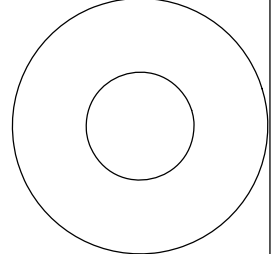

013-0102028
3/8"
CURVED WASHER

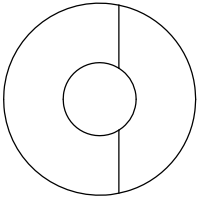

013-0402007
3/8"
FLAT WASHER
22mm O.D.

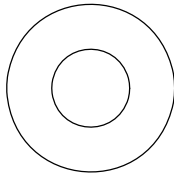

013-0102019
1/4"
LOCK WASHER



013-0102020
3/8"
LOCK WASHER

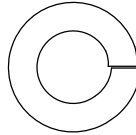

013-0102018
1/2"
LOCK WASHER

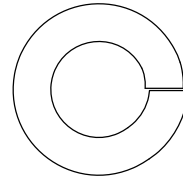

014-0018001
1/2" LONG
SPACER

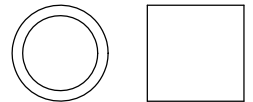

026-01M0238
2" ALUMINUM
FLATHEAD CAP

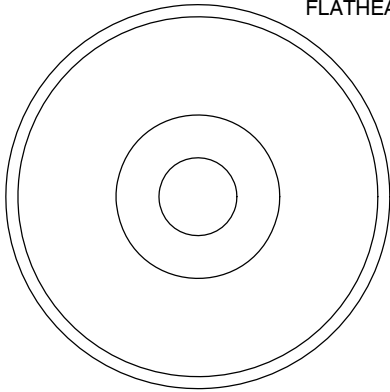

016-0009003
1" SHIM WASHER

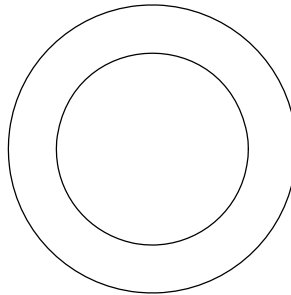

013-0003002
3/8" FENDER WASHER

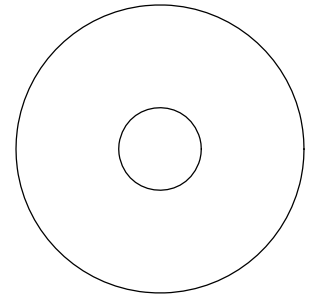

013-0003004
1 1/16"
FENDER WASHER

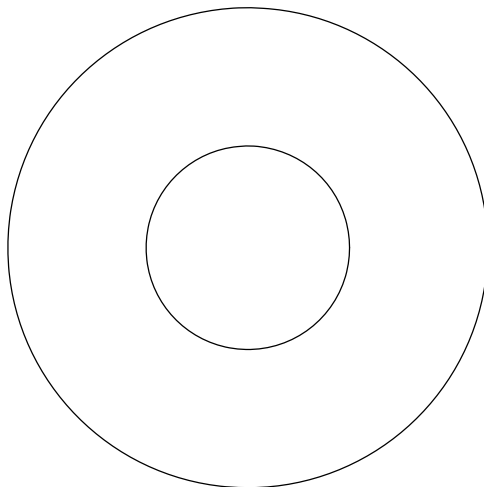

026-01PL151
PLASTIC 1 1/16"
FENDER WASHER

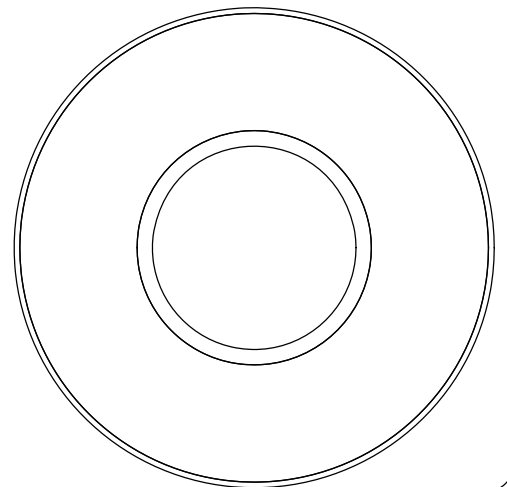

014-0018002
1" LONG
SPACER

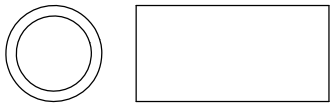

OWNER'S MANUAL

WASHER SIZING CHART (CONTINUED)

026-01M0211
1/4" LONG
FLANGED SPACER

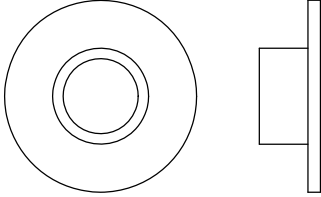

026-01M0198
1/2" LONG
FLANGED SPACER

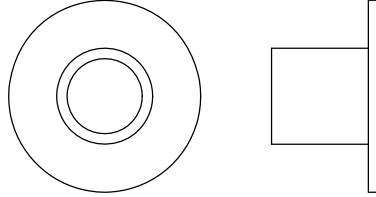

026-01M0760
1/2" LONG HEAVY
FLANGED SPACER

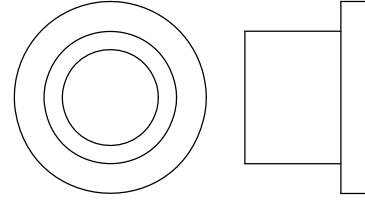

026-01M211T
1/4" LONG HEAVY
FLANGED SPACER

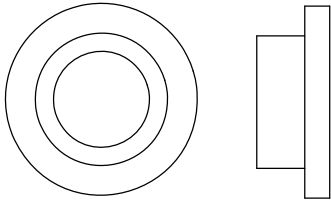

026-01M0532
11/16" LONG HEAVY
FLANGED SPACER

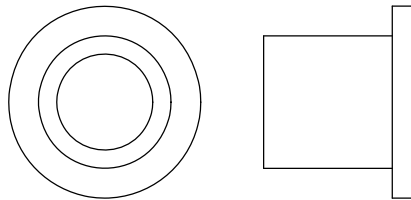

026-01M0551
1" LONG HEAVY
FLANGED SPACER

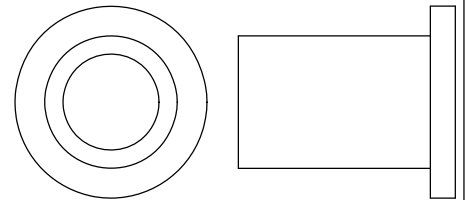

026-01M0788
.81" LONG HEAVY
FLANGED SPACER

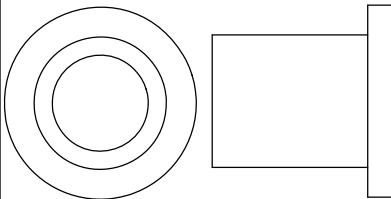

026-01M0780
.65" LONG HEAVY
FLANGED SPACER

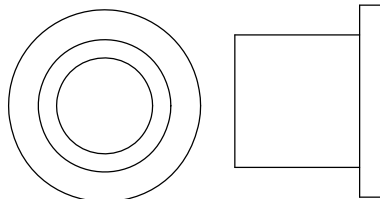

026-01M0761
1 11/16" LONG HEAVY
FLANGED SPACER

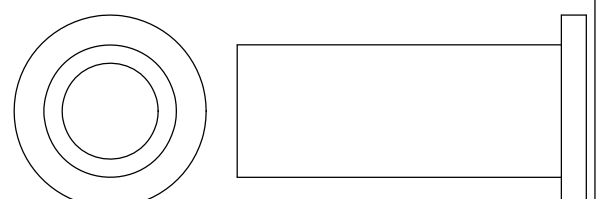

026-01M0789
.44" LONG HEAVY
FLANGED SPACER

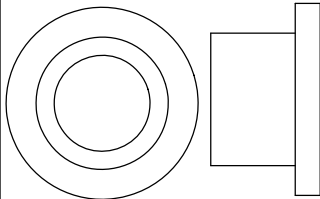

026-01M0762
1 1/2" LONG HEAVY
FLANGED SPACER

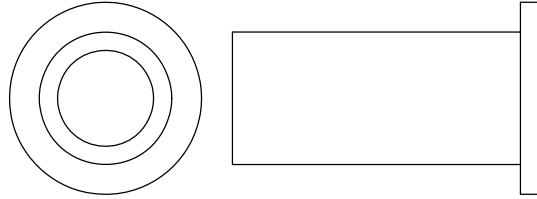

026-01M0768
1 1/4" LONG HEAVY
FLANGED SPACER

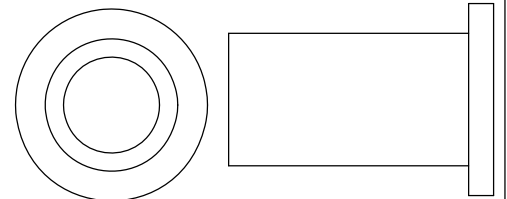

026-01M0600
.625" LONG
FLANGED SPACER

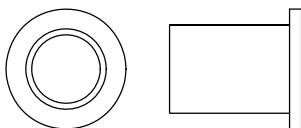

026-01M0240
1 3/8" ALUMINUM
FLATHEAD CAP

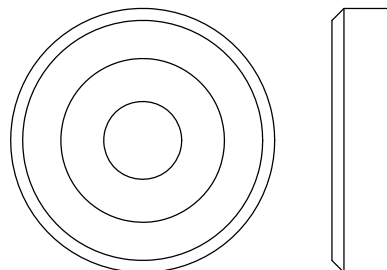

026-01M0239
1 5/8" ALUMINUM
FLATHEAD CAP

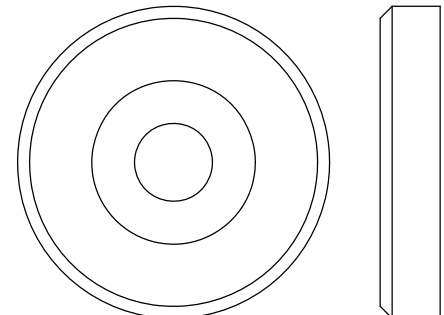

OWNER'S MANUAL

MAINTENANCE SCHEDULE

ROUTINE	COMMERCIAL / LIGHT COMMERCIAL MAINTENANCE	HOME MAINTENANCE	LATEST DATE ENTRY																	
Inspect; Links, Pull Pins, Snap Locks, Swivels, Weight Stack Pins	DAILY	WEEKLY																		
Clean; Upholstery	DAILY	WEEKLY																		
Inspect; Cables or Belts and their tension	DAILY	WEEKLY																		
Inspect; Accessory Bars, and Handles	WEEKLY	3 MONTHS																		
Inspect; All Decals	WEEKLY	3 MONTHS																		
Inspect; All Nuts and Bolts, Tighten if needed	WEEKLY	3 MONTHS																		
Inspect; Anti-Skid Surface	WEEKLY	3 MONTHS																		
Clean & Lubricate; Guide Rods with a Teflon (PTFE) based lubricant (Superlube)	MONTHLY	3 MONTHS																		
Lubricate; Seat Sleeves, Turcite Bushings, Linear Bearing	MONTHLY	3 MONTHS																		
Clean and Wax; All Glossy Finishes	6 MONTHS	YEARLY																		
Repack with Grease; Linear Bearings	6 MONTHS	YEARLY																		
Replace; Cables, Belts and Connecting Parts	YEARLY	3 YEARS																		

*Your equipment comes with a commercial maintenance decal.
For personal, in home use, please follow the home maintenance schedule listed above.*

Never use ammonia, acid-based, or petroleum-based solvents on any portion of the machine as it may damage the finish.

OWNER'S MANUAL

HOIST FITNESS SYSTEMS GENERAL MAINTENANCE INFORMATION

Links, Pull-Pins, Snap Hooks, Swivels, Weight Stack Pins:

- *Check all pieces for signs of visible wear or damage.
- *Check springs in snap hooks and pull-pins for proper tension and alignment.
- *If the spring sticks or has lost its rigidity, replace it immediately.

Upholstery:

- *To ensure prolonged upholstery life and proper hygiene, all upholstered pads should be wiped down with a damp cloth after every workout.
- *Periodically take the time to use a mild soap or an approved vinyl upholstery cleaner to deter the onset of cracking or drying. Avoid using any abrasive cleaners or cleaners not intended for use on vinyl.
- *Replace ripped or worn upholstery immediately.
- *Keep sharp or pointed objects clear of all upholstery.

Decals:

- *Inspect and familiarize yourself with any safety warnings or other user information posted on each decal.

Nuts and Bolts:

- *Inspect all nuts and bolts for any loosening and tighten if needed.
- *Go through a re-tightening sequence periodically to ensure that all hardware is tensioned proper.

Anti-Skid Surfaces:

- *These surfaces are designed to supply secure footing and need to be replaced if they appear worn or become slippery.

Belts and Cables:

- *Hoist uses only high quality belt, and mil-spec cables.
- *Visually inspect the belts and cables for fraying, cracking, peeling or discoloration.
- *While the machine is not in use, carefully run your fingers along the belt or cable to feel for thinning or bulging areas.
- *Replace belts and cables immediately at the first signs of damage or wear. Do not use equipment until belts or cables have been replaced.

Belt and Cable Tension:

- *Referring to the Owners Manual, when belts or cables are used check all bolts attachments to be sure they are properly attached.
- *Check slack in cables and re-adjust cable tension if needed.

Seat Sleeves, Guide Rods:

- *Wipe down adjusting tubes with a dust free rag before applying lubricant.
- *Lubricate seat sleeves and Guide Rods with a Silicon or Teflon based lubricant spray.

Linear Bearings:

- *Referring to the Owners Manual carefully disassemble the bearing from its housing and place a finger full of light grease (lithium, super lube, etc.) into the inside of the bearing. Using your finger, press the grease into the ball-bearings and their tracks. repeat until the ball-bearing tracks are full of grease. Insert the shaft back into the bearing and wipe off excess grease.

PLEASE KEEP THIS FOR YOUR RECORDS

OWNER'S MANUAL

WEIGHT TRAINING TIPS

Use this manual to guide you through the basic exercises you can perform on your HD-3403 HOIST® Fitness System. To gain maximum results and avoid possible injury, consult a fitness professional to develop your complete exercise program.

Always consult your physician before starting any exercise program.

To be successful in your exercise program, it is important to develop an understanding of the basic principles of strength training. Now that you have your HD-3403 HOIST® Fitness System, it is only natural that you want to get started immediately. First, determine a set of realistic goals and objectives for yourself. By deciding on an exercise plan that is right for you prior to starting, you will contribute significantly to your success.

Warm up properly before engaging in weight resistance training. Stretching, yoga, jogging, calisthenics or other cardiovascular exercise can help prepare your body for the heavier workload of lifting weights.

Learn how to perform the exercise correctly before using heavy weight. Correct form is important to avoid injury and to ensure that you work the proper muscle groups.

Know your limitations. If you are new to weight training or are embarking on an exercise regimen after a long layoff, start slowly and build foundational strength over a longer period of time.

Pay attention to your breathing. Exhale when you exert is a general rule of thumb. Never hold your breath.

Enjoy your HD-3403 HOIST® Fitness System!

OWNER'S MANUAL

WEIGHT RATIOS

NUMBER OF PLATES	LEG PRESS	TOE RAISE
	125%	130%
1	50	52
2	75	78
3	100	104
4	125	130
5	150	156
6	175	182
7	200	208
8	225	234
9	250	260
10	275	286
11	300	312
12	325	338
13	350	364
14	375	390
15	400	416
16	425	442
17	450	468
18	475	494

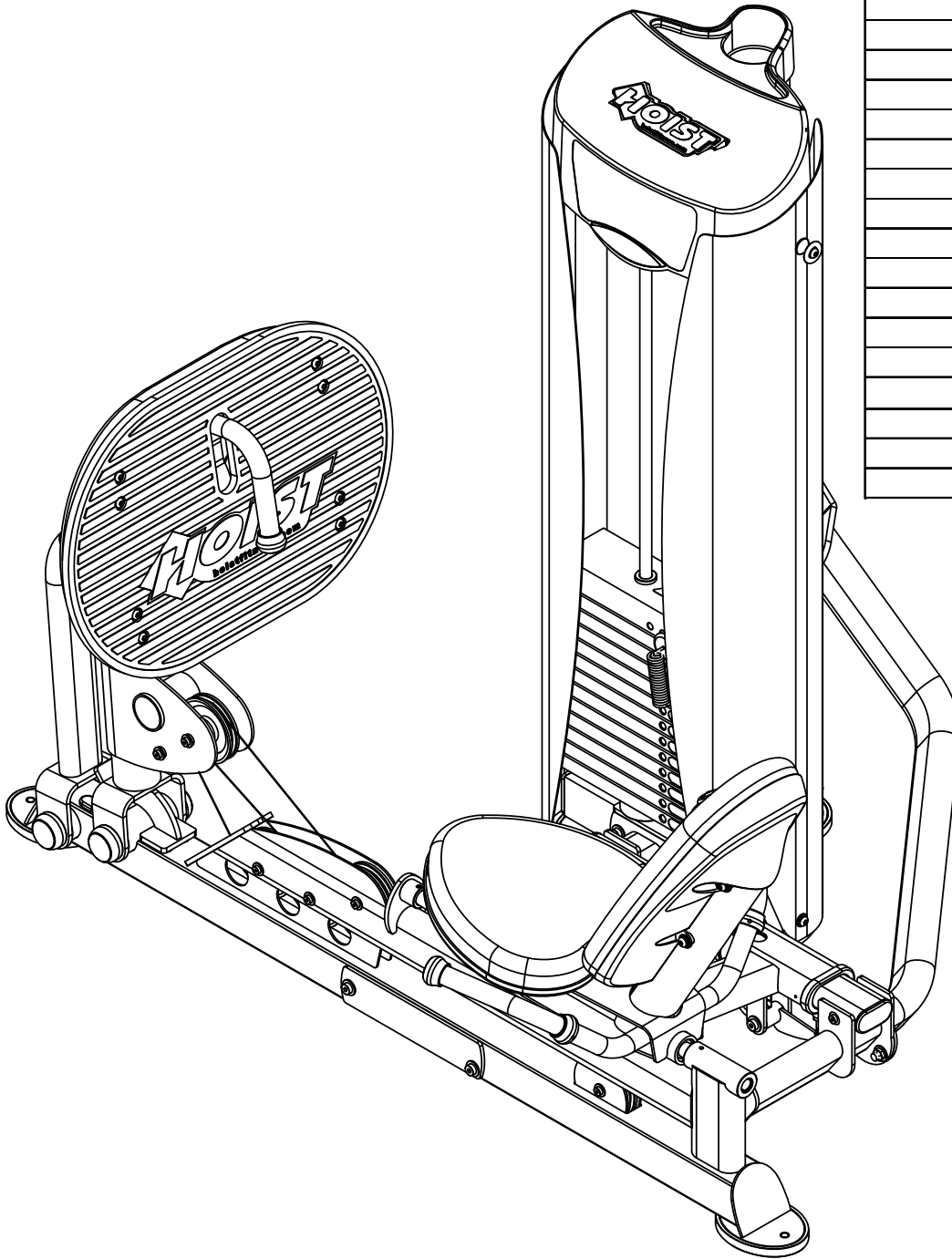

The above chart shows the standard weight stack for this unit. The weights listed are approximate. HOIST reserves the right to modify the machine without prior notice.

OWNER'S MANUAL

HOIST FITNESS SYSTEMS **LIMITED LIFETIME WARRANTY**

Hoist Fitness Systems warrants this product to the **original purchaser** to be free from defects in workmanship and/or materials under normal use or service. If at any time a component part is defective, Hoist Fitness Systems shall repair or replace it (at Hoist Fitness Systems option) within a reasonable period of time. This warranty does not cover costs of removal, transportation or reinstallation. This warranty shall not apply if the defect was caused by misuse, neglect or normal wear and tear.

WARRANTY CLAIMS. All claims require: Model number, Serial number, Date of installation, and any information supporting the existence of the alleged defect.

To complete Warranty Registration visit:

www.HOISTFITNESS.com

and click on the Warranty Registration link

Starting from the original date of purchase, normal wear and tear shall be considered as the following:

COMMERCIAL USE: All malfunctions of upholstery, grips, and coatings that occur up to one year; all malfunctions of belts, or **cables** up to one year; all malfunctions of pulleys, bearings, or bushings that occur up to three years. The frame and body components are warranted for ten years, with structural moving parts warranted for five years.

LIGHT COMMERCIAL USE: All malfunctions of upholstery, grips, and coatings that occur up to one year; all malfunctions of belts, or **cables** up to one year; all malfunctions of pulleys, bearings, or bushings that occur up to three years. The frame and body components are warranted for ten years, with structural moving parts warranted for five years.

HOME USE: All malfunctions of grips, paint, and chrome that occur up to ten years; all malfunctions of electronic components, belts, **cables**, or upholstery that occur up to ten years; all malfunctions of pulleys, bearings, or bushings that occur up to ten years. The frame and all welded components are warranted for the life of the product.

PLEASE NOTE THAT NOT ALL HOIST PRODUCTS ARE MADE FOR COMMERCIAL USE. Refer to the instructions page of your owners manual or consult with you fitness product dealer to establish if a product is made for commercial use or not. Using a non-commercial product in a commercial setting can result in serious injury or death! Hoist Fitness Systems sole responsibility shall be to repair or replace the component within the terms stated above. Hoist Fitness Systems shall not be liable for any loss or damage of any kind including any incidental or consequential damages resulting, directly or indirectly from any warranty expressed or implied or any other failure of this product.

LIGHT COMMERCIAL USE: Our Light Commercial warranty applies to facilities that **DO NOT** charge monthly membership dues and where the equipment would be used by **no more than 50** people per day. Examples of Light Commercial facilities include hotels, apartment complexes, personal training studios, fire stations, police stations, etc., that meet the criteria stated above.

WHAT IS NOT COVERED BY THIS WARRANTY: Hoist's sole obligation under this warranty is limited to either repair or replacement of parts, subject to the additions below. This warranty neither assumes nor authorizes any person to assume obligations other than expressly covered by this warranty.

NO CONSEQUENTIAL DAMAGES: Hoist is not responsible for economic loss; profit loss; or special, indirect, or consequential damages.

WARRANTY IS NOT TRANSFERABLE: This warranty is not assignable and applies only in favor of the original purchaser/user to whom delivered. Any such assignment or transfer shall void the warranties herein made and shall void all warranties, expressed, implied or statutory, except the one (1) and five (5) year warranties described above. These warranties are exclusive and in lieu of all other warranties, including implied warranty and merchantability or fitness for a particular purpose. There are no warranties which extend beyond the description on the face hereof.

TRANSPORTATION COSTS: Hoist will accept parts covered under this warranty freight collect, provided that shipment has received prior approval. Hoist is not responsible for any other transportation costs, but will ship freight collect parts either repaired or replaced under these warranties.

Hoist Fitness Systems
11900 Community Rd.
Poway, CA. 92064
(800)548-5438

PLEASE KEEP THIS FOR YOUR RECORDS